

IS

8251

8251-2

8251-3

8251-4

8251-5

Click on the  in the manual to watch the video tutorials.



Scan the QR code to go and subscribe our tutorial channel

vtech[®]

User's manual

Congratulations

on purchasing your new VTech product. Before using this telephone, please read Important safety instructions.

This manual has all the feature operations and troubleshooting necessary to install and operate your new VTech telephone. Please review this manual thoroughly to ensure proper installation and operation of this innovative and feature rich VTech product.

For support, shopping, and everything new at VTech, visit our website at www.vtechphones.com. In Canada, please visit phones.vtechcanada.com.



Telephones identified with this logo have reduced noise and interference when used with most T-coil equipped hearing aids and cochlear implants. The TIA-1083 Compliant Logo is a trademark of the Telecommunications Industry Association. Used under license.





The ENERGY STAR® program (www.energystar.gov) recognizes and encourages the use of products that save energy and help protect our environment. We are proud to mark this product with the ENERGY STAR® label indicating it meets the latest energy efficiency guidelines.

Important safety instructions

When using your telephone equipment, basic safety precautions should always be followed to reduce the risk of fire, electric shock and injury, including the following:

1. Read and understand all instructions.
2. Follow all warnings and instructions marked on the product.
3. Unplug this product from the wall outlet before cleaning. Do not use liquid or aerosol cleaners. Use a damp cloth for cleaning.
4. CAUTION: Do not install the telephone base at a height above 2 meters.
5. Do not use this product near water such as near a bath tub, wash bowl, kitchen sink, laundry tub or a swimming pool, or in a wet basement or shower.
6. Do not place this product on an unstable table, shelf, stand or other unstable surfaces.
7. Avoid placing the telephone system in places with extreme temperature, direct sunlight, or other electrical devices. Protect your phone from moisture, dust, corrosive liquids and fumes.
8. Slots and openings in the back or bottom of the telephone base and handset are provided for ventilation. To protect them from overheating, these openings must not be blocked by placing the product on a soft surface such as a bed, sofa or rug. This product should never be placed near or over a radiator or heat register. This product should not be placed in any area where proper ventilation is not provided.
9. This product should be operated only from the type of power source indicated on the marking label. If you are not sure of the type of power supply in your home or office, consult your dealer or local power company.
10. Do not allow anything to rest on the power cord. Do not install this product where the cord may be walked on.
11. Never push objects of any kind into this product through the slots in the telephone base or handset because they may touch dangerous voltage points or create a short circuit. Never spill liquid of any kind on the product.
12. To reduce the risk of electric shock, do not disassemble this product, but take it to an authorized service facility. Opening or removing parts of the telephone base or handset other than specified access doors may expose you to dangerous voltages or other risks. Incorrect reassembling can cause electric shock when the product is subsequently used.
13. Do not overload wall outlets and extension cords.
14. Unplug this product from the wall outlet and refer servicing to an authorized service facility under the following conditions:
 - When the power supply cord or plug is damaged or frayed.
 - If liquid has been spilled onto the product.
 - If the product has been exposed to rain or water.
 - If the product does not operate normally by following the operating instructions. Adjust only those controls that are covered by the operation instructions. Improper adjustment of other controls may result in damage and often requires extensive work by an authorized technician to restore the product to normal operation.
 - If the product has been dropped and the telephone base and/or handset has been damaged.
 - If the product exhibits a distinct change in performance.
15. Avoid using a telephone (other than cordless) during an electrical storm. There is a remote risk of electric shock from lightning.
16. Do not use the telephone to report a gas leak in the vicinity of the leak. Under certain circumstances, a spark may be created when the adapter is plugged into the power outlet, or when the handset is replaced in its cradle. This is a common event associated with the closing of any electrical circuit. The user should not plug the phone into a power outlet, and should not put a charged handset into the cradle, if the phone is located in an environment containing concentrations of flammable or flame-supporting gases, unless there is adequate ventilation. A spark in such an environment could create a fire or explosion. Such environments might include: medical use of oxygen without adequate ventilation; industrial gases (cleaning solvents; gasoline vapors; etc.); a leak of natural gas; etc.
17. Only put the handset of your telephone next to your ear when it is in normal talk mode.
18. The power adapter is intended to be correctly oriented in a vertical or floor mount position. The prongs are not designed to hold the plug in place if it is plugged into a ceiling, under-the-table or cabinet outlet.

19. For pluggable equipment, the socket outlet shall be installed near the equipment and shall be easily accessible.
20.   **CAUTION:** Use only the batteries indicated in this manual. There may be a risk of explosion if a wrong type of battery is used for the handset. Use only the supplied rechargeable batteries or replacement batteries (BT162342/ BT262342) for the handset. Do not dispose of batteries in a fire. They may explode. Dispose of used battery according to the instruction.
 - Do not use the battery in following conditions:
 - High or low extreme temperature during use, storage or transportation.
 - Replacement of a battery with an incorrect type that can defeat a safeguard.
 - Disposal of a battery into fire or a hot oven, or mechanically crushing or cutting of a battery, that can result in an explosion.
 - Leaving a battery in an extremely high temperature surrounding environment that can result in an explosion or the leakage of flammable liquid or gas.
 - A battery subjected to extremely low air pressure that can result in an explosion or the leakage of flammable liquid or gas.
21. Use only the adapter included with this product. Incorrect adapter polarity or voltage can seriously damage the product.
22. The applied nameplate is located at the bottom or near of the product.

SAVE THESE INSTRUCTIONS

Battery

- **CAUTION:** Use Only Supplied Battery. To order a replacement, visit our website at www.vtechphones.com or call 1 (800) 595-9511. In Canada, go to phones.vtechcanada.com or call 1 (800) 267-7377.
- Do not dispose of the battery in a fire. Check with local waste management codes for special disposal instructions.
- Do not open or mutilate the battery. Released electrolyte is corrosive and may cause burns or injury to the eyes or skin. The electrolyte may be toxic if swallowed.
- Exercise care in handling batteries in order not to create a short circuit with conductive materials.
- Charge the battery provided with this product

only in accordance with the instructions and limitations specified in this manual.

Precautions for users of implanted cardiac pacemakers

Cardiac pacemakers (applies only to digital cordless telephones):

Wireless Technology Research, LLC (WTR), an independent research entity, led a multidisciplinary evaluation of the interference between portable wireless telephones and implanted cardiac pacemakers. Supported by the U.S. Food and Drug Administration, WTR recommends to physicians that:

Pacemaker patients

- Should keep wireless telephones at least six inches from the pacemaker.
- Should NOT place wireless telephones directly over the pacemaker, such as in a breast pocket, when it is turned ON.
- Should use the wireless telephone at the ear opposite the pacemaker.

WTR's evaluation did not identify any risk to bystanders with pacemakers from other persons using wireless telephones.

About cordless telephones

- **Privacy:** The same features that make a cordless telephone convenient create some limitations. Telephone calls are transmitted between the telephone base and the cordless handset by radio waves, so there is a possibility that the cordless telephone conversations could be intercepted by radio receiving equipment within range of the cordless handset. For this reason, you should not think of cordless telephone conversations as being as private as those on corded telephones.
- **Electrical power:** The telephone base of this cordless telephone must be connected to a working electrical outlet. The electrical outlet should not be controlled by a wall switch. Calls cannot be made from the cordless handset if the telephone base is unplugged, switched off or if the electrical power is interrupted.
- **Potential TV interference:** Some cordless telephones operate at frequencies that may cause interference to televisions and VCRs. To minimize or prevent such interference, do not place the telephone base of the cordless telephone near or on top of a TV or VCR. If interference is

experienced, moving the cordless telephone farther away from the TV or VCR often reduces or eliminates the interference.

- **Rechargeable batteries:** Exercise care in handling batteries in order not to create a short circuit with conducting material such as rings, bracelets and keys. The battery or conductor may overheat and cause harm. Observe proper polarity between the battery and the battery charger.
- Nickel-metal hydride rechargeable batteries: Dispose of these batteries in a safe manner. Do not burn or puncture the battery. Like other batteries of this type, if burned or punctured, they could release caustic material which could cause injury.

ECO mode

This power conserving technology reduces power consumption for optimal battery performance. The ECO mode activities automatically whenever the handset is synchronized with the telephone base.

For C-UL compliance only

Mesures de sécurité importantes

Afin de réduire les risques d'incendie, de blessures corporelles ou d'électrocution, suivez toujours ces mesures préventives de base lorsque vous utilisez votre téléphone :

1. Lisez et comprenez bien toutes les instructions.
2. Observez toutes les instructions et mises en garde inscrites sur l'appareil.
3. Débranchez ce téléphone de la prise murale avant de le nettoyer. N'utilisez pas de nettoyeurs liquides ni en aérosol. N'utilisez qu'un chiffon doux et légèrement humecté.
4. ATTENTION: Ne pas installer le socle téléphonique à une hauteur supérieure à 2 mètres.
5. N'utilisez pas ce produit près de l'eau, tel que près d'un bain, d'un lavabo, d'un évier de cuisine, d'un bac de lavage ou d'une piscine, ou dans un sous-sol humide ou sous la douche.
6. Ne déposez pas ce téléphone sur un chariot, support ou table chancelants. L'appareil pourrait tomber et être sérieusement endommagé.
7. Évitez d'installer le système téléphonique dans les endroits soumis à une température extrême, à la lumière directe du soleil ou à proximité immédiate d'autres appareils électriques ou électroniques. Protégez votre téléphone contre les sources d'humidité, la poussière, les vapeurs et les liquides corrosifs.
8. Le boîtier de l'appareil est doté de fentes et d'ouvertures d'aération situées à l'arrière ou en dessous. Afin d'empêcher la surchauffe, ces ouvertures ne doivent pas être obstruées en plaçant l'appareil sur un lit, divan, tapis ou autre surface similaires. Ne placez pas cet appareil proximité d'un élément de chauffage ni d'une plinthe électrique. De plus, ne l'installez pas dans une unité murale ou un cabinet fermé qui ne possède pas d'aération adéquate.
9. Ne faites fonctionner cet appareil qu'avec le type d'alimentation indiqué sur les étiquettes de l'appareil. Si vous ne connaissez pas le voltage de

votre maison, consultez votre marchand ou votre fournisseur d'électricité.

10. Ne déposez rien sur le cordon d'alimentation. Installez cet appareil dans un endroit sécuritaire, là où personne ne pourra trébucher sur la ligne d'alimentation ni le cordon téléphonique modulaire.
11. N'insérez jamais d'objets à travers les fentes et ouvertures de cet appareil, car ils pourraient toucher à des points de tension dangereux ou court-circuiter des pièces, ce qui constituerait un risque d'incendie ou d'électrocution. N'échappez pas de liquides dans l'appareil.
12. Afin de réduire les risques d'électrocution, ne démontez pas l'appareil, mais apportez-le plutôt à un centre de service qualifié s'il doit être réparé. En enlevant le couvercle, vous vous exposez à des tensions dangereuses ou autres dangers similaires. Un remontage inadéquat peut être à l'origine d'une électrocution lors d'une utilisation ultérieure de l'appareil. Débranchez l'appareil avant de procéder au nettoyage. Utilisez un chiffon humide et doux.
13. Ne surchargez pas les prises de courant et les rallonges.
14. Débranchez cet appareil de la prise de courant et communiquez avec le département de service à la clientèle de VTech dans les cas suivants:
 - Lorsque le cordon d'alimentation est endommagé ou écorché.
 - Si du liquide a été échappé dans l'appareil.
 - Si l'appareil a été exposé une source d'humidité telle que la pluie ou l'eau.
 - Si le produit ne fonctionne pas normalement en respectant les instructions de fonctionnement. Réglez uniquement les commandes indiquées dans les instructions de fonctionnement. Les réglages incorrects des autres commandes pourraient provoquer un dommage qui pourrait exiger un travail exhaustif de la part d'un technicien autorisé afin de rétablir le fonctionnement normal de l'appareil.
 - Si le produit a été échappé et que le socle et/ou le combiné a été endommagé.
 - Si le produit affiche une nette diminution de sa performance.
15. Évitez d'utiliser un téléphone (autre qu'un sans fil) pendant un orage. Les éclairs peuvent être à l'origine d'une électrocution.
16. N'utilisez pas le téléphone pour rapporter une

fuite de gaz à proximité de la fuite. En certaines circonstances, une flammèche pourrait être provoquée lorsque l'adaptateur est branché à une prise de courant, ou lorsque le combiné est déposé sur le socle. Ceci est un événement commun associé à la fermeture d'un circuit électrique. L'utilisateur ne devrait pas brancher le téléphone à une prise de courant, et ne devrait pas déposer le combiné chargé sur le socle, si le téléphone se trouve à proximité d'un endroit comportant des concentrations de gaz inflammables, moins que la ventilation soit adéquate. Une flammèche dans un tel endroit pourrait provoquer un incendie ou une explosion. De tels environnements peuvent comprendre: des endroits où l'on utilise de l'oxygène médical sans ventilation adéquate; des gaz industriels (dissolvants de nettoyage, des vapeurs d'essence, etc.); une fuite de gaz naturel, etc.

17. Ne placez que le combiné de votre téléphone près de votre oreille lorsqu'en mode de conversation.
18. Ces adaptateurs ont été conçus pour être orientés en position verticale ou montés au sol. Les broches ne sont pas conçues pour maintenir l'adaptateur en place si celui-ci est branché dans une prise au plafond ou sous une table/ armoire.
19. Pour le MATERIEL RACCORDE PAR PRISE DE COURANT, le socle de prise de courant doit être installé à proximité du matériel et doit être aisément accessible.



MISE EN GARDE: Il peut y avoir un risque d'explosion si vous utilisez le mauvais type de piles pour le téléphone. N'utilisez que les piles rechargeable inclus ou les piles de rechange (BT162342/BT262342). N'incinerez pas les piles. Celles-ci risqueraient d'exploser. Mettre au rebut les batteries usagées conformément aux instructions du fabricant.

- Évitez d'utiliser la batterie dans les conditions suivantes:
 - des températures extrêmes faibles ou élevées auxquelles une batterie peut être soumise pendant l'utilisation, le stockage ou le transport.
 - remplacement d'une batterie par un type incorrect pouvant supprimer une protection.
 - mise au rebut d'une batterie dans un feu ou dans un four chaud, ou écrasement mécanique ou coupure d'une batterie, susceptible de provoquer une explosion.
 - maintiend'une batterie dans un environnement

à très haute température pouvant provoquer une explosion ou la fuite de liquide ou de gaz inflammables.

- batterie soumise à une pression de l'air extrêmement faible pouvant provoquer une explosion ou la fuite de liquide ou de gaz inflammables.

21. N'utilisez que les adaptateurs inclus avec ce produit. L'utilisation d'un adaptateur dont la polarité ou la tension serait inadéquate risque d'endommager sérieusement le produit et mettre votre sécurité en péril.

22. La plaque signalétique appliquée est située au bas ou à proximité du produit.

CONSERVEZ CES INSTRUCTIONS

Pile

- N'utilisez que la pile incluse ou l'équivalent. Pour commander une pile de recharge, visitez notre site Web au www.vtechphones.com ou composez le 800-595-9511. Au Canada, visitez le phones.vtechcanada.com ou composez le 800-267-7377.
- Ne jetez pas la pile au feu. Vérifiez les instructions spécifiques de mise aux rebus auprès des autorités locales.
- N'ouvrez pas et ne mutilez pas la pile. L'électrolyte qui s'en échapperait est corrosif et pourrait causer des brûlures ou des blessures aux yeux ou à la peau. L'électrolyte est toxique si avalé.
- Soyez prudents lorsque vous manipulez les piles afin d'éviter les courts-circuits provoqués par des matériaux conducteurs.
- Rechargez la pile incluse avec cet appareil, selon les instructions et limites spécifiées dans ce guide d'utilisation.

Stimulateurs cardiaques implantés dans l'organisme

Les simulateurs cardiaques (s'applique uniquement aux téléphones numériques sans fil):

L'organisme 'Wireless Technology Research, LLC (WTR)', une firme de recherche indépendante, a mené une évaluation pluridisciplinaire des interférences entre les téléphones sans fil portatifs et les stimulateurs cardiaques implantés dans l'organisme. Appuyée par l'Administration des aliments et drogues (FDA) des États-Unis, la firme WTR recommande aux médecins:

Avis aux détenteurs de stimulateurs cardiaques

- Ils doivent tenir le téléphone sans fil à une distance d'au moins six pouces du stimulateur cardiaque.
- Ils ne doivent PAS placer le téléphone sans fil directement sur le stimulateur cardiaque, tel que dans une poche de chemise, lorsque celui-ci est en marche.
- Ils doivent utiliser le téléphone sans fil en l'appuyant sur l'oreille qui se trouve dans la direction opposée au stimulateur cardiaque.

L'étude effectuée par l'organisme WRS n'a pas identifié de risque pour les détenteurs de simulateurs cardiaques causés par les gens qui utilisent un téléphone sans fil à proximité de ceux-ci.

À propos des téléphones sans fil

- Alimentation électrique: Les mêmes caractéristiques qui constituent des avantages pour les téléphones sans fil affichent également des restrictions. Les appels téléphoniques sont transmis entre le combiné sans fil et le socle par le biais d'ondes radio ; il y a donc la possibilité que vos conversations téléphoniques sans fil soient interceptées par des équipements de réception radio se trouvant dans la portée du combiné sans fil. Pour cette raison, vous ne devez pas percevoir les communications téléphoniques sans fil comme étant aussi confidentielles.
- Alimentation électrique: Le socle de ce téléphone sans fil doit être branché à une prise électrique fonctionnelle. La prise électrique ne doit pas être contrôlée par un interrupteur mural. Les appels ne pourront pas être effectués du combiné sans fil si le socle est débranché ou mis hors tension ou si le courant est coupé.
- Possibilité d'interférences aux téléviseurs: Certains téléphones sans fil fonctionnent sur des fréquences pouvant causer des interférences aux téléviseurs et aux magnétoscopes. Pour réduire ou prévenir de telles interférences, ne placez pas le socle du téléphone sans fil près ou sur un téléviseur ou magnétoscope. S'il y a présence de parasites, il est conseillé d'éloigner le téléphone sans fil du téléviseur ou du magnétoscope afin de réduire possiblement les interférences.
- Piles rechargeables: Manipulez les piles avec soin afin de ne pas les court-circuiter avec des bagues, bracelets ou clés. Les piles ou le conducteur peut surchauffer et causer des blessures. Respectez la

polarité adéquate entre la pile et le chargeur.

- Les bloc-piles rechargeables à l'hydrure métallique de nickel: Jetez ces blocs-piles de manière écologique et sécuritaire. Ne les incinerez pas et ne les percez pas. Tel que les autres piles de ce type, elles pourraient dégager une matière toxique qui peut causer des blessures corporelles si elles sont brûlées ou percées.

The RBRC® seal

The RBRC® seal on the nickel-metal hydride battery indicates that VTech Communications, Inc. is voluntarily participating in an industry program to collect and recycle these batteries at the end of their useful lives, when taken out of service within the United States and Canada.

The RBRC® program provides a convenient alternative to placing used nickel-metal hydride batteries into the trash or municipal waste, which may be illegal in your area.

VTech's participation in RBRC® makes it easy for you to drop off the spent battery at local retailers participating in the RBRC® program or at authorized VTech product service centers. Please call

1 (800) 8 BATTERY® for information on Ni-MH battery recycling and disposal bans/restrictions in your area.

VTech's involvement in this program is part of its commitment to protecting our environment and conserving natural resources.

RBRC® and 1 (800) 8 BATTERY® are registered trademarks of Call2recycle, Inc.



FCC, ACTA and IC regulations FCC Part 15

This equipment has been tested and found to comply with the requirements for a Class B digital device under Part 15 of the Federal Communications Commission (FCC) rules. These requirements are intended to provide reasonable protection against harmful interference in a residential installation. This equipment generates, uses and can radiate radio frequency energy and, if not installed and used in accordance with the instructions, may cause harmful interference to radio communications. However, there is no guarantee that interference will not occur in a particular installation. If this equipment does cause harmful interference to radio or television reception, which can be determined by turning the equipment off and on, the user is encouraged to try to correct the interference by one or more of the following measures:

- Reorient or relocate the receiving antenna.
- Increase the separation between the equipment and receiver.
- Connect the equipment into an outlet on a circuit different from that to which the receiver is connected.
- Consult the dealer or an experienced radio/TV technician for help.

Changes or modifications to this equipment not expressly approved by the party responsible for compliance could void the user's authority to operate the equipment.

This device complies with Part 15 of the FCC rules. Operation is subject to the following two conditions: (1) this device may not cause harmful interference, and (2) this device must accept any interference received, including interference that may cause undesired operation. Privacy of communications may not be ensured when using this telephone.

To ensure safety of users, the FCC/ISED has established criteria for the amount of radio frequency energy that can be safely absorbed by a user or bystander according to the intended usage of the product. This product has been tested and found to comply with the FCC/ISED criteria. The handset may be safely held against the ear of the user. The telephone base shall be installed and used such that parts of the user's body other than the hands are maintained at a distance of approximately 20 cm (8 inches) or more.

This Class B digital apparatus complies with Canadian requirement:

CAN ICES-3 (B)/NMB-3(B).

FCC Part 68 and ACTA

This equipment complies with Part 68 of the FCC rules and with technical requirements adopted by the Administrative Council for Terminal Attachments (ACTA). The label on the back or bottom of this equipment contains, among other things, a product identifier in the format US:AAAEQ##TXXXX. This identifier must be provided to your telephone service provider upon request.

The plug and jack used to connect this equipment to premises wiring and the telephone network must comply with applicable Part 68 rules and technical requirements adopted by ACTA. A compliant telephone cord and modular plug is provided with this product. It is designed to be connected to a compatible modular jack that is also compliant. An RJ11 jack should normally be used for connecting to a single line and an RJ14 jack for two lines. See the installation instructions in the user's manual.

The Ringer Equivalence Number (REN) is used to determine how many devices you may connect to your telephone line and still have them ring when you are called. The REN for this product is encoded as the 6th and 7th characters following the US: in the product identifier (e.g., if ## is 03, the REN is 0.3). In most, but not all areas, the sum of all RENs should be five (5.0) or less. For more information, please contact your telephone service provider.

This equipment may not be used with Party Lines. If you have specially wired alarm dialing equipment connected to your telephone line, ensure the connection of this equipment does not disable your alarm equipment. If you have questions about what will disable alarm equipment, consult your telephone service provider or a qualified installer.

If this equipment is malfunctioning, it must be unplugged from the modular jack until the problem has been corrected. Replacement to this telephone equipment can only be made by the manufacturer or its authorized agents. For replacement procedures, follow the instructions outlined under the "Limited warranty".

If this equipment is causing harm to the telephone network, the telephone service provider may temporarily discontinue your telephone service. The telephone service provider is required to notify you before interrupting service. If advance notice is not

practical, you will be notified as soon as possible. You will be given the opportunity to correct the problem and the telephone service provider is required to inform you of your right to file a complaint with the FCC. Your telephone service provider may make changes in its facilities, equipment, operation, or procedures that could affect the proper functioning of this product. The telephone service provider is required to notify you if such changes are planned.

If this product is equipped with a corded or cordless handset, it is hearing aid compatible.

If this product has memory dialing locations, you may choose to store emergency telephone numbers (e.g., police, fire, medical) in these locations. If you do store or test emergency numbers, please:

Remain on the line and briefly explain the reason for the call before hanging up.

Perform such activities in off-peak hours, such as early morning or late evening.

Industry Canada

This device contains licence-exempt transmitter(s)/ receiver(s) that comply with Innovation, Science and Economic Development Canada's licence-exempt RSS(s).

Operation is subject to the following two conditions: (1) this device may not cause interference, and (2) this device must accept any interference, including interference that may cause undesired operation.

Privacy of communications may not be ensured when using this telephone.

The term "IC:" before the certification/registration number only signifies that the Industry Canada technical specifications were met.

The Ringer Equivalence Number (REN) for this terminal equipment is 1.0. The REN is an indication of the maximum number of devices allowed to be connected to a telephone interface. The termination on an interface may consist of any combination of devices subject only to the requirement that the sum of the RENs of all the devices does not exceed five.

This product meets the applicable Innovation, Science and Economic Development Canada technical specifications.

Install Set up	16	Phonebook	29
What's in the box	16	Update the Smart key speed dial number/ entry	30
Connect the telephone base	17	Add an emergency number	30
Connect the charger	17	Add a menu option	30
Install the battery	17	Change a smart key function	31
Charge the battery	18	Edit a speed dial number	31
Check the battery level	18	Edit an emergency number	32
Display	19	Delete a speed dial number	32
Handset	19	Delete an emergency number	32
Telephone base	19	Bluetooth	33
Check for a dial tone	20	Add a Bluetooth cell phone/ headset	33
Before use	20	Cell phone	33
Set date and time	20	Headset	34
Set up Smart call blocker*	21	Download your cell phone phonebook using the base	34
Set up Answering system	21	Disconnect/ Reconnect your Bluetooth device	35
Install	22	Edit / remove your Bluetooth cell phone or headset	35
Mount the telephone base (Optional)	22	Auto Bluetooth connection	35
Overview	22	Activate remove voice control	36
Telephone base	22	Handset	36
Handset	25	Base	36
Charger	27	Use phone menu	36
Operating range	27	On the handset	36
Telephone base features menu	28	On the base	36
Handset features menu	28		
Smart keys	29		
Add a speed dial number	29		
Add a speed dial number via			

Contents

Operate	37	Sound	41
Make, answer or end a cell call	37	Use speakerphone	41
Make a cell call	37	Mute the microphone	41
Predial a cell call	37	Temporary ringer silencing	42
Answer a cell call	37	Find handset	42
End a cell call	37	Page/ find handset	42
Make, answer, or end a home call	38	Phonebook Phonebook entry	43
Make a home call	38	Add a phonebook entry with a handset	43
Predial a home call	38	Add a phonebook entry with base	43
Answer a home call	38	Review the phonebook entries with a handset	45
End a home call	38	Review the phonebook entries with base	45
Using a Bluetooth headset to answer a home call	38	Option 1	45
Answer or end a home call using a Bluetooth headset	38	Option 2	45
View dialing options	39	Option 3	45
Option while on a call	39	Dial a phonebook entry with a handset	45
Join a call	39	Dial a phonebook entry with base	46
Join a call in progress	39	Option 1	46
Intercom	40	Option 2	46
Initiate an intercom call on the handset	40	Delete a phonebook entry with a handset	46
Initiate an intercom call on the base	40	Delete all phonebook entries with a handset	47
Answer an intercom call	40		
End an intercom call	40		
Transfer a call via intercom	41		

Delete a phonebook entry with base	47	Chain dialing	52
Delete all phonebook entries with base	47	Access a number in the phonebook with a handset while on a call	52
Edit a phonebook entry with a handset	47	Access a number in the phonebook with base while on a call	52
Edit a phonebook entry with base	48	Access a number in the caller ID log with a handset while on a call	53
Alphabetical search with a handset	49	Access a number in the caller ID log with base while on a call	53
Alphabetical search with base	49	Access the redial list with a handset while on a call	53
Redial list	50	Access the redial list with base while on a call	53
Dial a redial list entry with a handset	50	Caller ID	54
Dial a redial list entry with base	50	Handset	54
Review a redial list entry with a handset	50	Review the caller ID log entry	54
Review a redial list entry with base	50	Save a caller ID log entry to the phonebook	54
Delete a redial list entry with a handset	50	Save a caller ID log entry to the block list	55
Delete a redial list entry with base	50	Save a caller ID log entry to the star name list	56
Call waiting	51	Delete caller ID log entries	56
Call waiting on the cell line	51		
Call waiting on the home line	51		
Predial via home call and cell call	52		
Predial a home call	52		
Predial a cell call	52		

Contents

Base	56	Delete all messages	65
Review the caller ID log entry	56	Handset	65
Save a caller ID log entry to the phonebook	56	Base	65
Save a caller ID log entry to the block list	58	Answering system remote access	65
Save a caller ID log entry to the star name list	58	Call intercept while using answering system	66
Dial a caller ID log entry	59	Recording memo	66
Caller ID memory match	59	Handset	66
Missed call indicator	60	Base	66
Set CID time sync	60	Turn on/ off the call screening	67
Answering system	61	Handset	67
About the built-in answering system and voicemail service	61	Base	67
Built-in answering system VS voicemail service	61	Screen a call with answering system	67
Use your built-in answering system	62	Voicemail (via Telephone service provider)	68
Turn on or off the answering system	62	Turn off the new voicemail indicators	68
Handset	62	Activate and use cell phone's voice app via handset/ telephone base	69
Base	63	Announcement	71
Set number of rings	63	Handset	71
Handset	63	Base	73
Base	63		
Message playback	64		
Handset	64		
Base	64		

Smart call blocker (SCB)	76	Ringers	88
Handset - Method 1	76	Set home/cell ring volume	88
Handset - Method 2	76	Handset	88
Base	76	Base	88
Set SCB screening profile	77	Set home/ cell ringtone	89
Handset	77	Handset	89
Base	78	Base	90
Set up Block list	79	Date and time	90
Handset	79	Set date and time	90
Base	80	Handset	90
Smart call blocker settings	82	Base	91
Star name entry/ list	82	LCD languages	91
Handset	82	Select LCD language	91
Base	84	Handset	91
Answering system settings	85	Base	91
Set your built-in answering system	85	Sound settings	92
Set answering system through voice guide	85	Set QUIET mode	92
Change remote access code	85	Adjust listening volume	93
Handset	85	Handset	93
Base	85	Base	93
Turn on or off the message alert tone	86	Set key tone	93
Handset	86	Handset	93
Base	86	Base	93
Dial modes	87		
Temporary tone dialing	87		
Set dial mode	87		

Contents

Other settings	94
Clear voicemail	94
Dim mode	94
Brightness	94
Wallpaper	94
Countdown timer	95
Set the countdown timer	95
General product care	96
Taking care of your telephone	96
Avoid rough treatment	96
Avoid water	96
Electrical storms	96
Cleaning your telephone	96
Technical specifications	97
Frequently asked questions	97

Install | Set up

What's in the box

Your telephone package contains the following items. Save your sales receipt and original packaging in case it is necessary to ship your telephone for warranty service.

You can add new handsets (IS8251/ IS8251-2/ IS8251-3/ IS8251-4/ IS8251-5) to your telephone system. All accessories are sold separately. Your telephone base supports a maximum of five devices

NOTE

- To purchase replacement batteries or power adapters, visit our website at www.vtechphones.com or call 1 (800) 595-9511. In Canada, go to phones.vtechcanada.com or dial 1 (800) 267-7377.

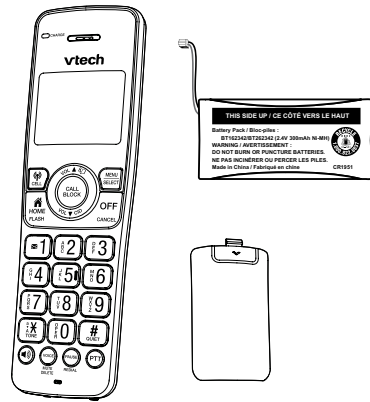
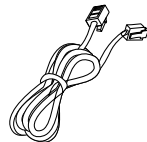
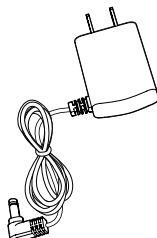
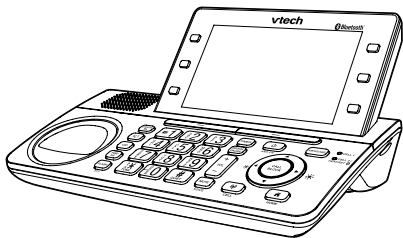

- 2 set for IS8251-2
- 3 sets for IS8251-3
- 4 sets for IS8251-4
- 5 sets for IS8251-5

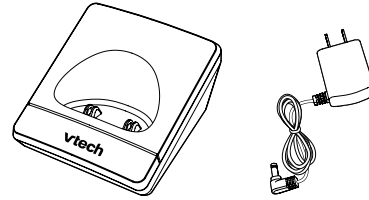

- 1 set for IS8251-2
- 2 sets for IS8251-3
- 3 sets for IS8251-4
- 4 sets for IS8251-5

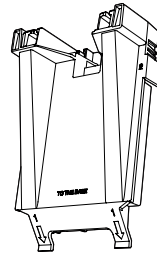

- **Sold separately**
- To purchase in the US, go visit www.vtechphones.com or call **1 (800) 595-9511**.
- To purchase in Canada, go visit phones.vtechcanada.com or call 1 (800) 267-7377.

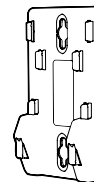

Model: **W2001**
Wall mount
installation (Optional)



Your telephone base is ready for tabletop use. If you want to mount your telephone on a wall, use the wall-mount bracket (sold separately) to attach to a standard dual-stud telephone wall-mounting plate.

If you do not have this wall-mounting plate, you can purchase one from many hardware or consumer electronics retailers. You may need a professional to install the wall-mounting plate.

Connect the telephone base

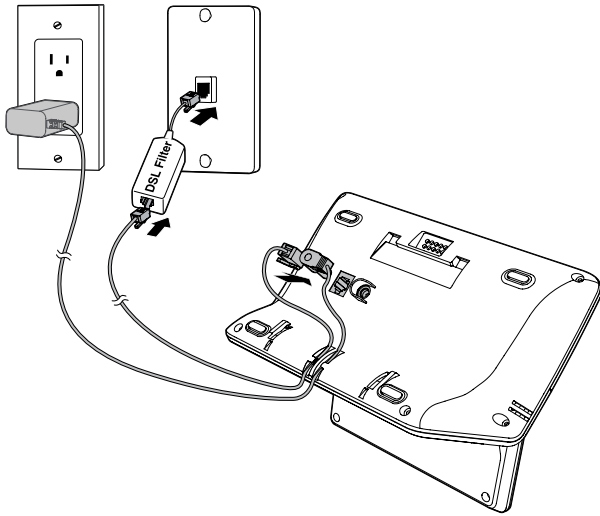

TIPS

- If you want to mount the base, make sure telephone line pass through the mounting bracket before connecting to the DSL filter.
- If you subscribe to digital subscriber line (DSL) high-speed Internet service through your telephone line, make sure you connect a DSL filter (not included) to the telephone wall jack.

Connect the charger

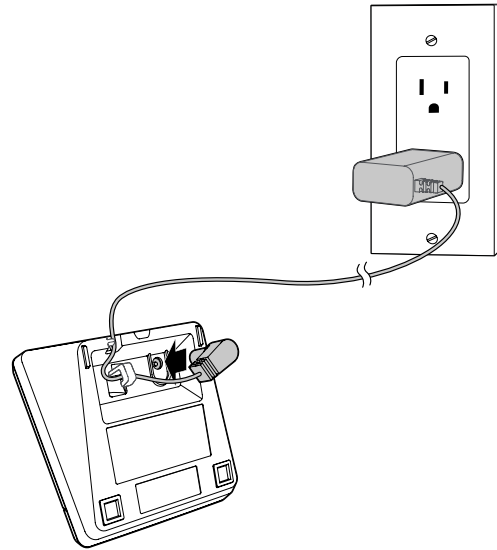

Install the battery

1. Plug the battery connector securely into the socket inside the handset battery compartment.
 - Make sure the battery label **THIS SIDE UP** is facing up, as indicated.

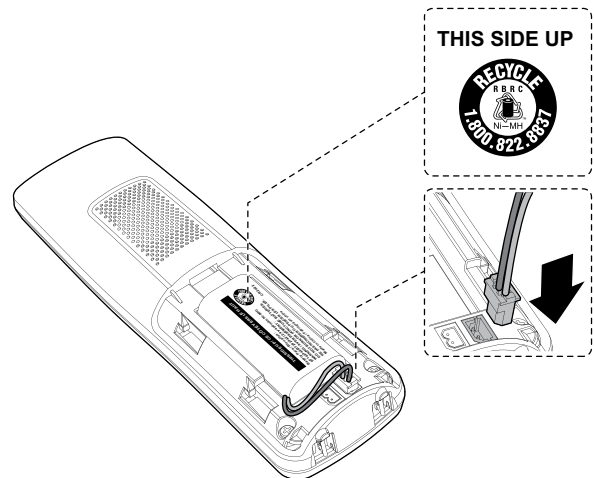

- Align the cover flat against the battery compartment, then slide it upwards until it clicks into place.

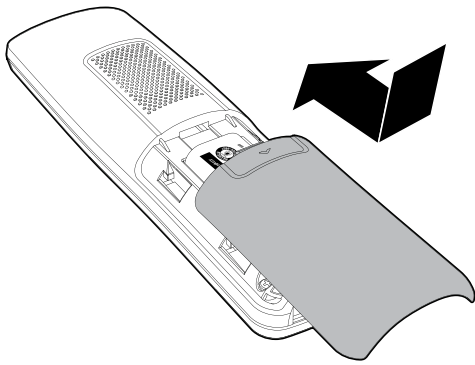

<ul style="list-style-type: none"> The screen shows HANDSET X. 	<ul style="list-style-type: none"> The battery is charged. 	<ul style="list-style-type: none"> To keep the battery charged, place it in the handset charger when not in use.
--	---	---

When it is fully charged, you can expect the following performance:

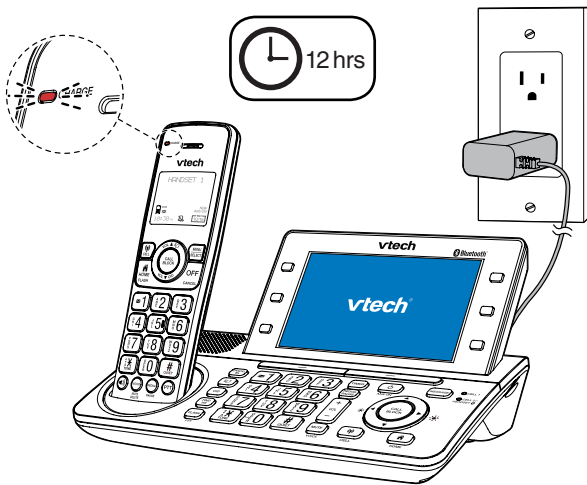

Charge the battery



Operation	• Operating time *
Talk time (cordless handset)	• 10 hours
Talk time (cordless handset speakerphone)	• 4.5 hours
Standby	• 5 days





* Operating times vary depending on your actual use and the age of the battery.

The following table summarizes the battery indicators and actions to take.

Battery indicators	Battery status	Action
<ul style="list-style-type: none"> The screen is blank, or shows Put in charger and  flashes. 	<ul style="list-style-type: none"> The battery has no charge or very little charge. The handset cannot be used. 	<ul style="list-style-type: none"> Charge without interruption (at least 30 minutes).
<ul style="list-style-type: none"> The screen shows Low battery and  flashes. 	<ul style="list-style-type: none"> The battery has enough charge to be used for a short time. 	<ul style="list-style-type: none"> Charge without interruption (at least 30 minutes).

Check the battery level

After you have installed the battery, check the battery level on the handset screen.

- If the screen is blank, or  flashes, then the battery needs to be charged. Go to **Charge the battery** section before you do any setting or operation.
- If the battery icon is , , or , then go to **Set date and time**, **Set up Answering system**, and **Set up Smart call blocker*** through voice guide section.

Display

Handset



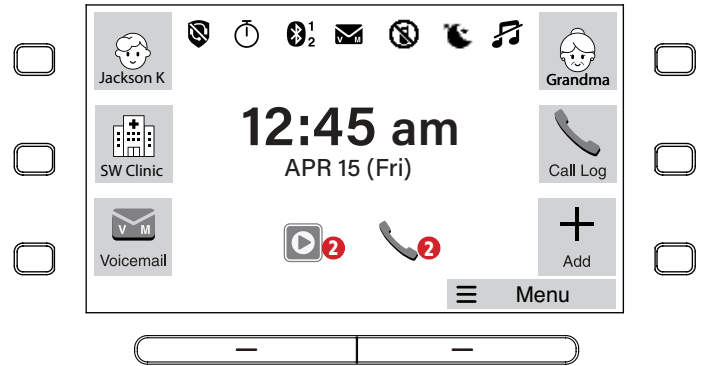

	• The handset battery is low and needs charging.
	• The handset battery is charging.
	• The handset battery is fully charged.
ECO	• The ECO mode activates automatically to reduce power consumption when the handset is within range of the telephone base.
	• New voicemail received from your telephone service provider.
	• Displays when Home line is in use.
	• Bluetooth device is paired and active.
	• Bluetooth device / Cell line is in use.
NEW	• There are new caller ID log entries
ANS ON	• Answering system is on.
10:30 AM	• Time with AM and PM.
	• Handset or telephone base ringer is off.
MSG # 10/16	• Handset displays the current message number being played and the total number of new/old messages recorded.

Telephone base



Smart key(s) 	<ul style="list-style-type: none"> • Configurable shortcut of menu option(s), e.g. speed dial number, emergency call, message list, phonebook, intercom, smart call blocker, call log, bluetooth, timer, ringer, setting, etc. • Option displays next to a smart key. Press it to select.
Softkey(s) 	<ul style="list-style-type: none"> • Press a softkey to select the option displays above.
Menu	<ul style="list-style-type: none"> • Option(s) displays above a softkey.
	<ul style="list-style-type: none"> • Smart call blocker is on.
	<ul style="list-style-type: none"> • Timer is set and counting down. • Flashes when the countdown reaches.
	<ul style="list-style-type: none"> • Bluetooth device is paired and active.
	<ul style="list-style-type: none"> • Bluetooth device is in use.
	<ul style="list-style-type: none"> • Wireless Bluetooth headset is in use.
	<ul style="list-style-type: none"> • New voicemail received from your telephone service provider.
	<ul style="list-style-type: none"> • Push to Talk is off.
	<ul style="list-style-type: none"> • Quiet mode is on for the selected period of time.
	<ul style="list-style-type: none"> • Telephone base ringer is off.
	<ul style="list-style-type: none"> • Displays when Home line is in use.
	<ul style="list-style-type: none"> • New messages and the total number of new messages displays next to it.
	<ul style="list-style-type: none"> • Missed calls and the total number of missed calls displays next to it.

Check for a dial tone

Press  on the handset or  on the base. If you hear a dial tone, the installation is successful.

If you do not hear a dial tone

- Make sure the installation procedures are properly done.
- The handset may take a second or two to find the telephone base and produce a dial tone. This is normal. Wait an extra second before dialing.
- If the previous suggestions do not work, disconnect the telephone line cord from your telephone and connect the telephone line cord to another telephone.
- If there is no dial tone on that other telephone either, your telephone line cord may be defective. Install a new telephone line cord.
- If changing the telephone line cord does not help, the wall jack (or the wiring to this wall jack) may be defective. Try using a different wall jack in your home to connect your IS8251, IS8251-2, IS8251-3, IS8251-4, and IS8251-5 telephone, or contact your telephone service provider (charges may apply).

Before use



After you install your telephone or power returns following a power outage and battery depletion, the handset will prompt you to set the date and time, and to configure the Smart call blocker* and answering system through voice guide.

Set date and time

NOTE

- Make sure you set the date and time including the year correctly; otherwise the answering system does not announce the correct day of the week for your recorded messages time stamp.

Handset

1. Use the dialing keys (**0-9**) to enter the date (**MM/DD/YY**), and then press  to confirm.
2. Use the dialing keys (**0-9**) to enter the time (**HH:MM**), and then press  to confirm.



Base

1. Use the dialing keys (**0-9**) to enter the month (**MM**), date (**DD**) and year (**YY**). Then, press **Next**.
2. Use the dialing keys (**0-9**) to enter the hour (**HH**) and minute (**MM**). Then, press **▲/▼** to choose **AM** or **PM**.
3. Press **Save** to save.

*Includes licenced Galtel™ technology. Galtel™ is a trademark of Truecall Group Limited.

After setting the date and time, the base will prompt if you want to set **Set up Smart call blocker***.

TIP

- To skip setting the date and time, press  on the handset or  on the base.

Set up Smart call blocker*

After the date and time setting is done or skipped, the base will prompt if you want to set Smart call blocker. Press **Yes** to start the Smart call blocker setup via voice guide.

This feature is an easy and alternative way for you to do the basic setup of Smart call blocker. You can follow the voice guide to set your telephone system to allow or to screen all incoming home calls, or to screen home calls that do not display a phone number.

You hear a voice prompt *"Hello! This voice guide will assist you with the basic setup of Smart call blocker..."*

Set up your Smart call blocker feature by inputting the designated numbers, as instructed in the voice guide.

- To skip the set up, press .
- Press **1** if you want to screen home calls with telephone numbers that are not saved in your directory, allow list or star name list; or
- Press **2** if you do not want to screen calls, and want to allow all incoming calls to get through.

NOTE

- The screening feature of Smart call blocker is applicable to home calls only. All incoming cell calls will get through and ring. If you want to block a cell call, add the number to the block list. See **Set up Block list**.

Set up Answering system

After the Smart call blocker setting is done or skipped, the base will then prompt and ask whether you want to set up the answering system.

Base

Press **Yes** to start the answering system setup via voice guide. You hear a voice prompt *"This voice guide will assist you with the basic setup of your answering system..."*

- To skip the set up, press .

You can record your own announcement, set the number of rings, and set the message alert tone.

Set your own announcement

- Press **7** to record your own announcement, or press **9** to use the standard announcement *"Hello! Please leave a message after the tone..."* and skip to next item - **Set QUIET mode**.

Set number of rings

- Press **2**, **3**, **4**, **5** or **6** for your preferred number of rings, or **8** for toll saver.
 - Displays and confirms the number of rings being set.

Set message alert tone

When there is at least one new message, the base beeps every 10 seconds. You can press **1** for **On** or **0** for **Off**.

Install



Mount the telephone base (Optional)



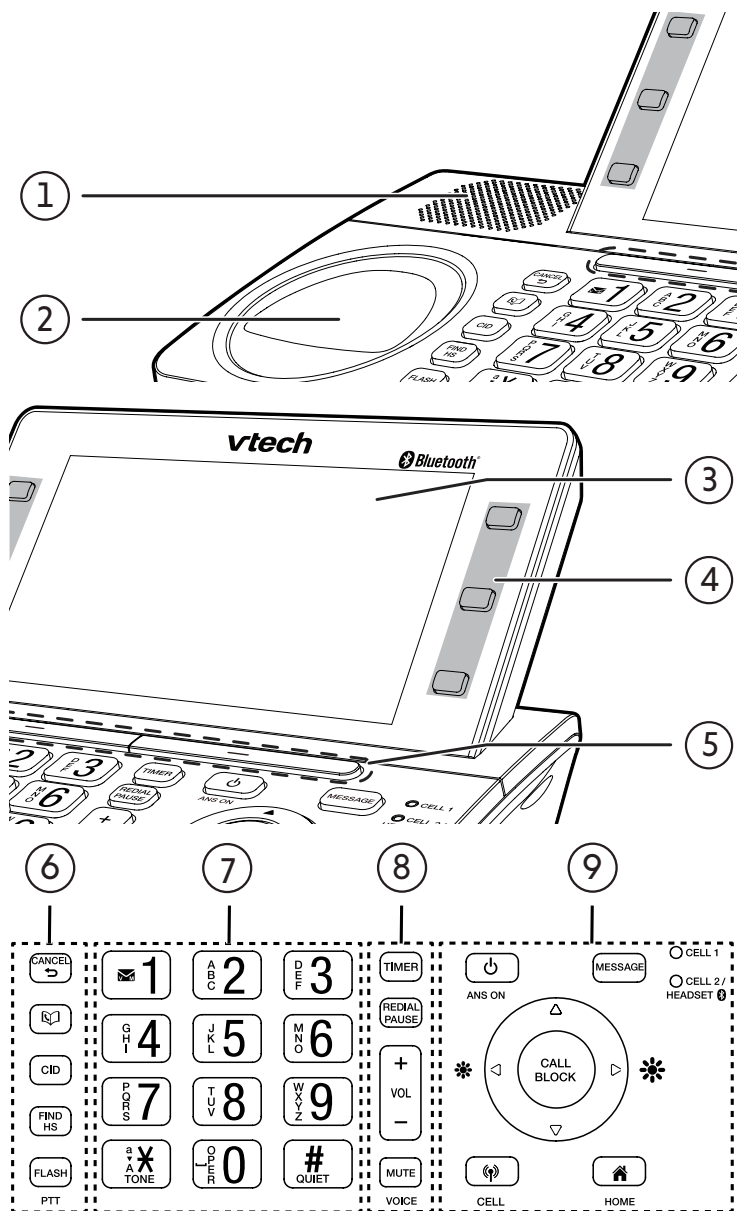

Your telephone base is ready for tabletop use. If you want to mount your telephone on a wall, use the wall-mount bracket (**sold separately**) to attach to a standard dual-stud telephone wall-mounting plate. See **What's in the box** for details. If you do not have this wall-mounting plate, you can purchase one from many hardware or consumer electronics retailers. You may need a professional to install the wall-mounting plate.





Overview





Telephone base









1	• Speaker
2	• Cradle with charging pole
3	• LCD display
4	 <ul style="list-style-type: none"> • Smart keys
5	 <ul style="list-style-type: none"> • Softkeys - Options display above a softkey.

6		<ul style="list-style-type: none"> While in a menu, press to cancel an operation, back up to the previous menu, or exit the menu display; or <u>press and hold</u> this button to exit to idle mode.
		<ul style="list-style-type: none"> Press to show phonebook entries when the telephone is not in use.
		<ul style="list-style-type: none"> Press to review the caller ID log when the telephone is not in use.
		<ul style="list-style-type: none"> Press to page all handsets.
		<ul style="list-style-type: none"> During a call, press to answer an incoming home call when you receive a call waiting alert. <u>Press and hold</u> to broadcast to a group of system devices, i.e. to initiate a one-to-one or one-to-group broadcast. Press to display the PTT menu to begin a PTT call.

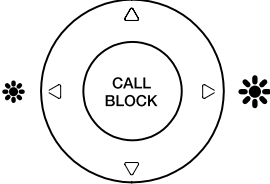
7	<ul style="list-style-type: none"> Keypad 	
		<ul style="list-style-type: none"> While reviewing a caller ID log entry, press repeatedly to add or remove 1 in front of the telephone number before dialing or saving it in the phonebook. <u>Press and hold</u> to set or dial your voicemail number.
		<ul style="list-style-type: none"> Press to switch to tone dialing temporarily during a call if you have pulse service. While entering names, press to change the next letter to upper or lower case.
		<ul style="list-style-type: none"> While entering names or numbers, press to add a spacing.
		<ul style="list-style-type: none"> <u>Press and hold</u> to set and turn on the QUIET mode, or turn it off. Press to enter # key during a call. Press repeatedly to show other dialing options when reviewing a caller ID log entry.

	<ul style="list-style-type: none"> • Press to enter COUNTDOWN TIMER.
	<ul style="list-style-type: none"> • Press repeatedly to view the last 10 numbers dialed. • While entering numbers, <u>press and hold</u> to insert a dialing pause.
	<ul style="list-style-type: none"> • VOL + <ul style="list-style-type: none"> • Press to increase the listening volume when on a call, or increase the message playback volume. • VOL - <ul style="list-style-type: none"> • Press to decrease the listening volume when on a call, or decrease the message playback volume.
	<ul style="list-style-type: none"> • During a call, press to mute the microphone. • When the handset is ringing, press to mute the ringer temporarily. • During message or announcement playback, press to delete the playing message or the recorded announcement.

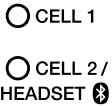
	<ul style="list-style-type: none"> • Press to turn on the answering system.
	<ul style="list-style-type: none"> • Press to start or stop message playback.
	<ul style="list-style-type: none"> • CALL BLOCK <ul style="list-style-type: none"> • When the telephone is ringing, press to block the incoming home call or cell call. • When on a home call or cell call, press to block the call. •  <ul style="list-style-type: none"> • Adjust LCD display brightness. • Press left to dim, and press right to increase the LCD brightness. •  <ul style="list-style-type: none"> • Press to navigate in the menu options.
	<ul style="list-style-type: none"> • Press to make or answer a cell call. • During a call, press to answer an incoming cell call when you hear a call waiting alert.
	<ul style="list-style-type: none"> • Press to make or answer a home call. • During a call, press to answer an incoming home call when you receive a call waiting alert.
	<ul style="list-style-type: none"> • Illuminate when bluetooth device(s) are paired to the system.

Handset

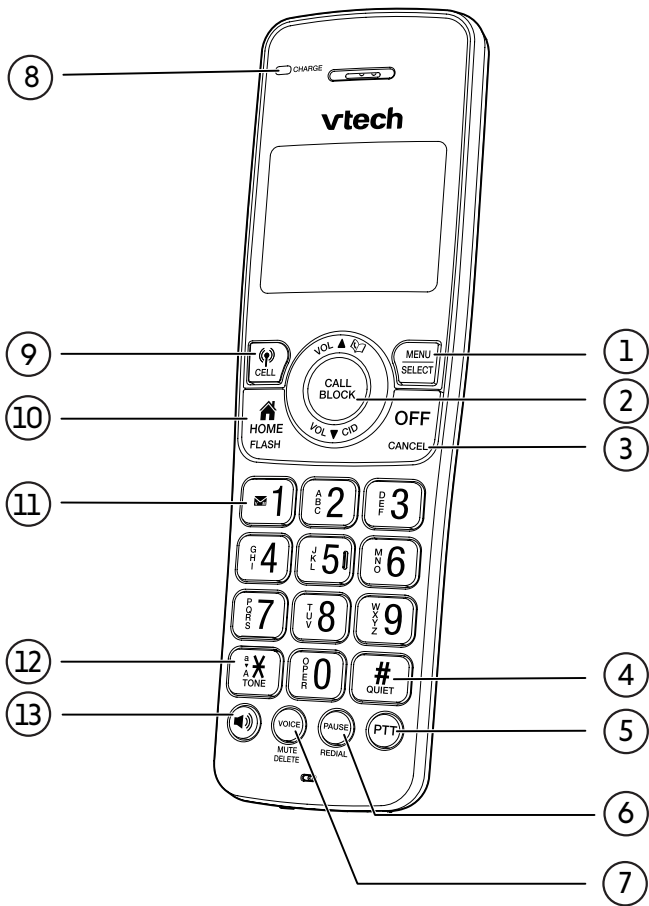

1



- Press to display the menu.
- Once in the menu, press to select an item or save an entry or setting.



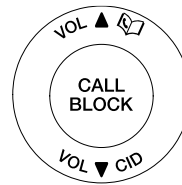



2







- **VOL ▲**
 - Press to show phonebook entries when the telephone is not in use.
 - Press to scroll up while in a menu.
 - Press to increase the listening volume when on a call, or increase the message playback volume.
 - While entering names or numbers, press to move the cursor to the right.

- **CALL BLOCK**
 - When the telephone is ringing, press to block the incoming home call or cell call.
 - When on a home call or cell call, press to block the call.

- **VOL ▼ CID**
 - Press to review the caller ID log when the telephone is not in use.
 - Press to scroll down while in a menu.
 - Press to decrease the listening volume when on a call, or decrease the message playback volume.
 - While entering names or numbers, press to move the cursor to the left.

3		<ul style="list-style-type: none"> • During a call, press to hang up. • While in a menu, press to cancel an operation, back up to the previous menu, or exit the menu display; or <u>press and hold</u> this button to exit to idle mode. • When the handset is ringing, press to mute the ringer temporarily. • <u>Press and hold</u> while the handset is not in use to erase the missed call indicator.
4		<ul style="list-style-type: none"> • <u>Press and hold</u> to set and turn on the QUIET mode, or turn it off. • When reviewing a caller ID log entry, press repeatedly to view other dialing options.
5		<ul style="list-style-type: none"> • Press to initiate a one-to-one or one-to-group broadcast. • <u>Press and hold</u> to broadcast to a group of system devices.
6		<ul style="list-style-type: none"> • Press repeatedly to view the last 10 numbers dialed. • While entering numbers, <u>press and hold</u> to insert a dialing pause.
7		<ul style="list-style-type: none"> • VOICE <ul style="list-style-type: none"> • While connected to one or two cell phones, press to activate the voice controlled application of one of the connected cell phones. • MUTE / DELETE <ul style="list-style-type: none"> • During a call, press to mute the microphone. • When the handset is ringing, press to mute the ringer temporarily. • While reviewing the redial list, phonebook, caller ID log, allow list, block list, or the star name list, press to delete an individual entry. • While predialing, press to delete digits. • When entering names or numbers, press to delete a digit or character. • When entering names or numbers, press and hold to erase all digits or characters. • During message or announcement playback, press to delete the playing message or the recorded announcement.
8	CHARGE light	<ul style="list-style-type: none"> • On when the handset is charging in the telephone base or charger.
9		<ul style="list-style-type: none"> • Press to make or answer a cell call. • During a call, press to answer an incoming cell call when you hear a call waiting alert.



10		<ul style="list-style-type: none"> • Press to make or answer a home call. • During a call, press to answer an incoming home call when you receive a call waiting alert.
11		<ul style="list-style-type: none"> • While reviewing a caller ID log entry, press repeatedly to add or remove 1 in front of the telephone number before dialing or saving it in the phonebook. • <u>Press and hold</u> to set or dial your voicemail number.
12		<ul style="list-style-type: none"> • Press to switch to tone dialing temporarily during a call if you have pulse service. • While entering names, press to change the next letter to upper or lower case.
13		<ul style="list-style-type: none"> • Press to make or answer a call using the speakerphone. • Press to turn on the handset speakerphone, press again to resume normal handset use.

Operating range

This cordless telephone operates with the maximum power allowed by the Federal Communications Commission (FCC). Even so, this handset and telephone base can communicate over only a certain distance which can vary with the locations of the telephone base and handset, the weather, and the layout of your home or office.

When the handset is out of range, the handset displays **Out of range OR no power at base.**

If there is a call while the handset is out of range, it may not ring, or if it does ring, the call may not connect well when you

press . Move closer to the telephone base, and then press  to answer the call. If the handset moves out of range during a telephone conversation, there may be interference. To improve reception, move closer to the telephone base.

Charger

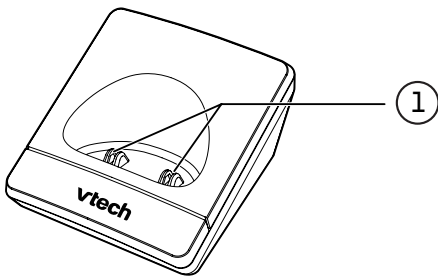

1 Charging pole

Telephone base features menu

Here is the overview of the telephone base features menu.

1. Press **Menu**.
 - You will then enter the menu page. There are 2 pages.
2. Press **Next** or **Previous** to review the features menu.
 - You can also press \triangle/∇ .

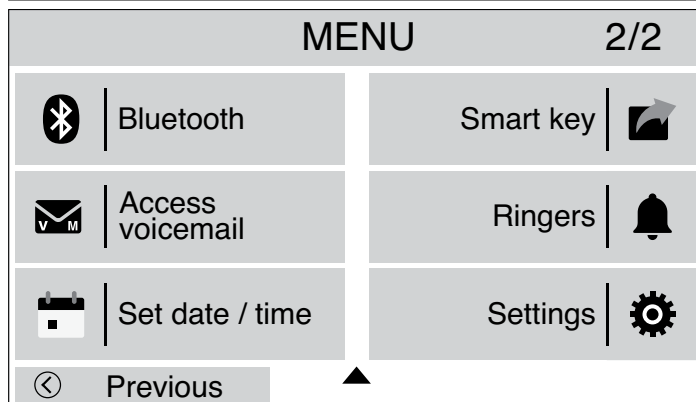
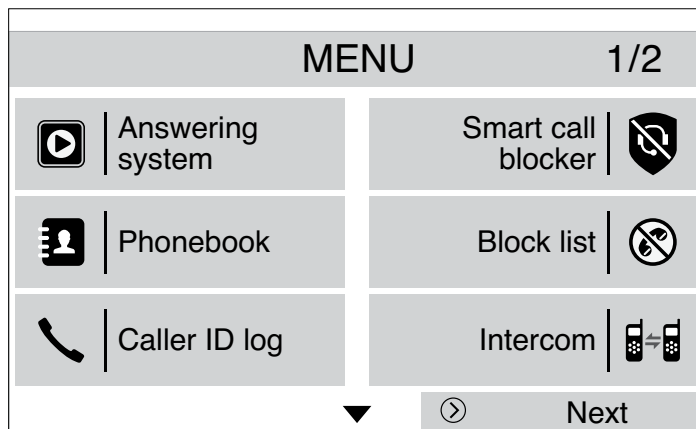
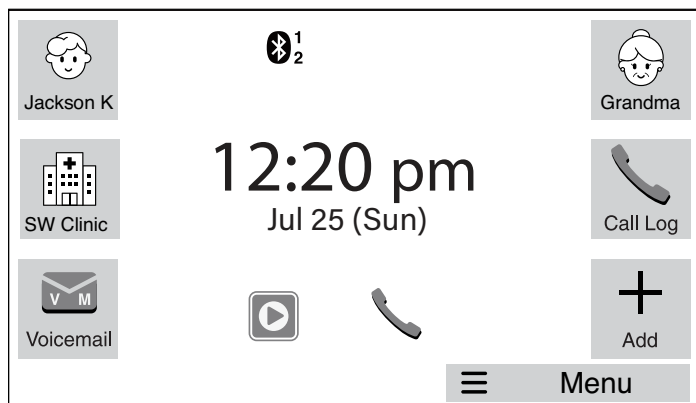

Handset features menu

Here is the overview of the handset features menu.

1. Press **MENU SELECT**.
 - You will then enter the menu list.
2. Press $\blacktriangle/\blacktriangledown$ to review the handset features menu.



◆ Answering sys

◆ SOB screening

◆ SOB settings

◆ Block list

◆ Phonebook

◆ Caller ID log

◆ Intercom

◆ Ringers

◆ Set date/time

◆ Caller ID ann

◆ Settings

Smart keys

On the telephone base, there are six Smart keys along the left and right of the LCD screen.

Smart keys allow you to access the speed dial number, emergency number and other menu options quickly. You can reset the Smart keys anytime you want.

Add a speed dial number

1. Press **+ Add** to add a Smart key function.
2. Press **Speed dial** .

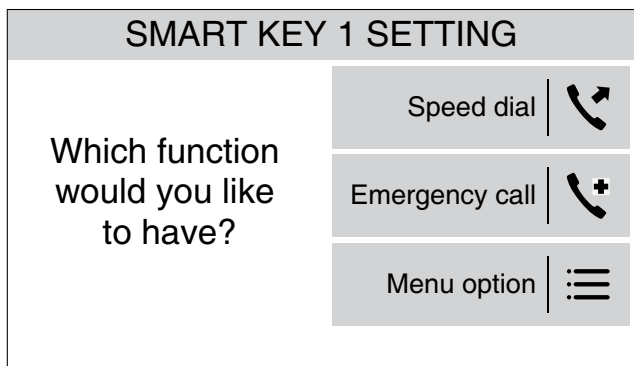

3. Enter the speed dial number, and then press **Next**.
4. Enter the name, and then press **Next**.
5. Press $\triangleleft/\triangle/\nabla/\triangleright$ to select a desired profile picture, and then press **Select**.

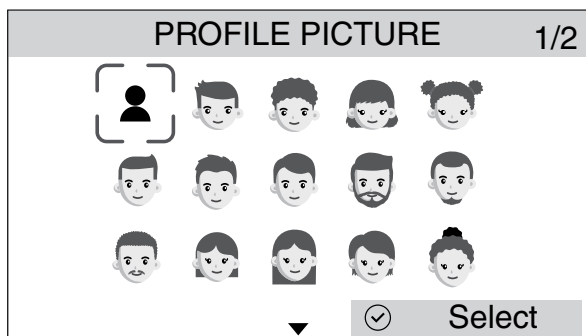

6. Press $\triangleleft/\triangle/\nabla/\triangleright$ to select a desired color tone, then press **Select**.

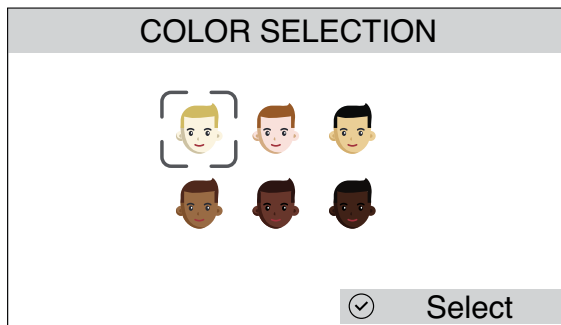

7. Press **Yes** to save.

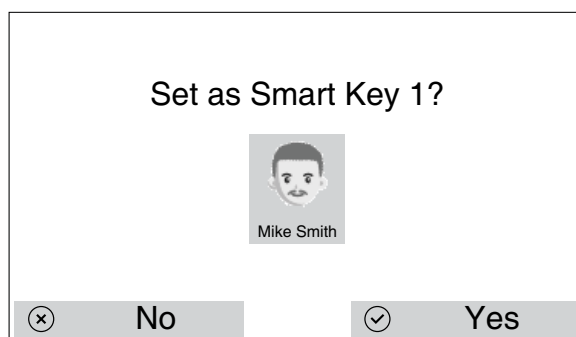

Add a speed dial number via Phonebook

1. Press **+ Add** to add a Smart key function.
2. Press **Speed dial** .

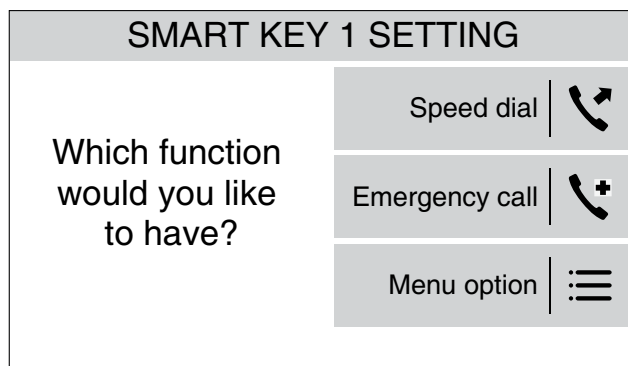

3. Press **Copy from Phonebook** .

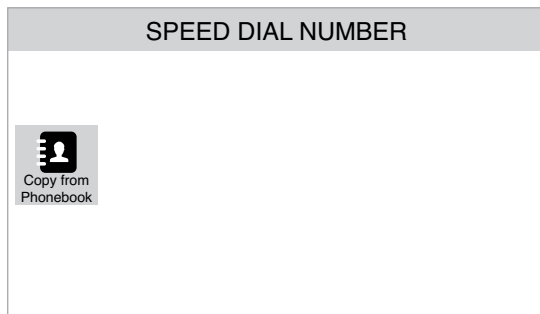

4. Press **▶** smart key next to your desired entry.

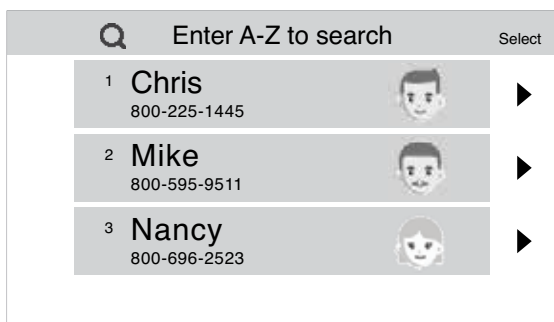

5. Press **Yes** to save.



NOTE

- The Smart key speed dial number copies from the Phonebook at the time. It does not auto-update/synchronize, even if the entries in the Phonebook have changed since then. You need to update it separately.

Update the Smart key speed dial number/ entry

1. Press softkey **Menu** and then \triangle/∇ to scroll to the **Smart key** , and then press its smart key to enter.
2. Press the smart key speed dial contact you want to change.
3. Press **Edit** and then update the telephone number (if required). Press **Next**.
4. Update the name (if required). Press **Next**.
5. Select a new **Profile Picture** (if required). Press **Select**.
6. Select a new **Color Section** (if required). Press **Select**.
7. Press **Yes** to save the updated entry.

Add an emergency number

1. Press **+ Add** to add a Smart key function.
2. Press **Emergency call** .
3. Enter the emergency number, and then press **Save**.

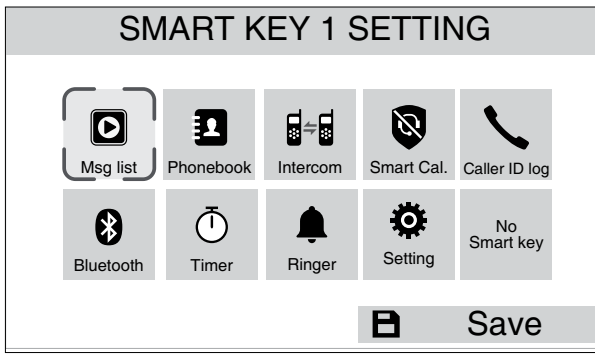

Add a menu option

1. Press **+ Add** to add a Smart key function.
2. Press **Menu option** .
3. Press $\triangleleft/\triangle/\nabla/\triangleright$ to choose your desired menu option, and then press **Save**.



Change a smart key function

You may want to change your existing smart key to another. For instance, from Phonebook to a speed dial number, an emergency number, or another menu option.

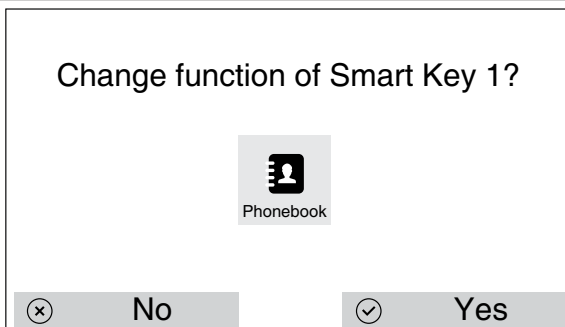
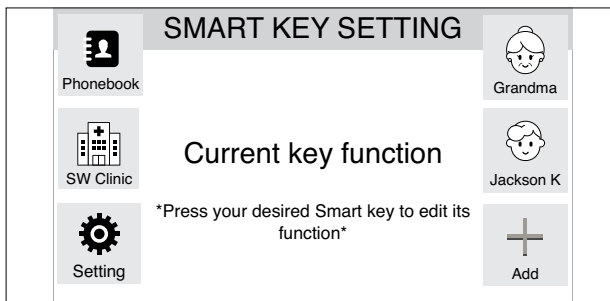

1. Press softkey **Menu** on the telephone base.
2. Press Δ/∇ to scroll to the **Smart key** , and then press its smart key to enter.
3. Press the Smart key you want to change. For instance: **Phonebook** .



4. Press **Yes** to confirm changing.
5. Now, select your desired Smart key function.

Follow the steps in **Add a speed dial number**, **Add an emergency number**, or **Add a menu option** sections to change.



Edit a speed dial number

1. Press **Menu** on the telephone base.
2. Press Δ/∇ to scroll to the **Smart key** , and then press its  to enter.
3. Press the speed dial contact you want to change. It will then ask you whether you want to change.



4. Press **Edit** .
5. Edit the number if needed, and then press **Next**.
6. Edit the name if needed, and then press **Next**.
7. Select profile picture if needed, and then press **Select**.
8. Select color tone if needed, and then press **Select**.
9. Press **Yes** to confirm and save the edit.

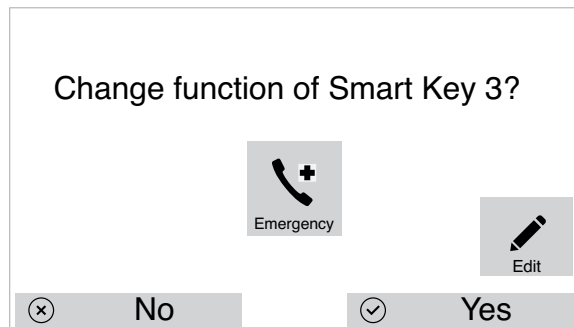

Edit an emergency number

1. Press **Menu** on the telephone base.
2. Press \triangle/∇ to scroll to the **Smart key** , and then press its  to enter.
3. Press the emergency number you want to change. It will then ask you whether you want to change.



4. Press **Edit** .
5. Edit the number if needed, and then press **Save** to confirm and save.

Delete a speed dial number

1. Press **Menu** on the telephone base.
2. Press \triangle/∇ to scroll to the **Smart key** , and then press its  to enter.
3. Press the speed dial contact you want to delete.

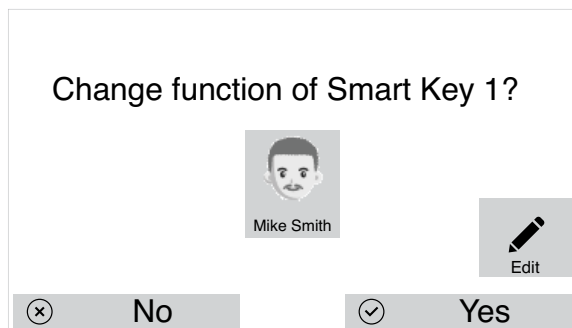

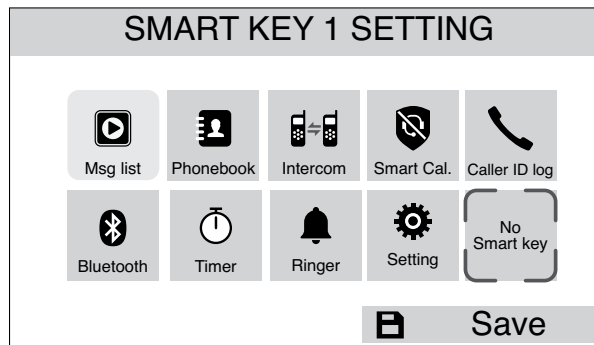

4. Press **Yes**.
5. Press **Menu option** .

6. Press $\triangleleft/\triangle/\nabla/\triangleright$ to choose **No Smart key**, and then press **Save**.



Delete an emergency number

1. Press **Menu** on the telephone base.
2. Press \triangle/∇ to scroll to the **Smart key** , and then press its  to enter.
3. Press the emergency number you want to delete.

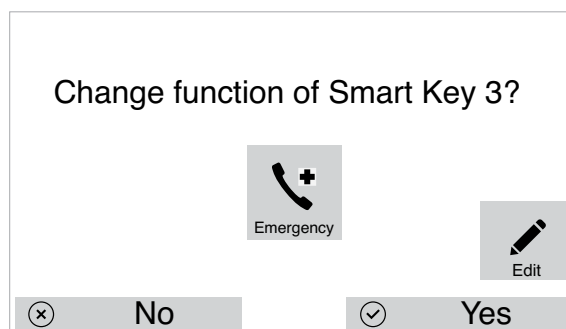

4. Press **Yes**.
5. Press **Menu option** .
6. Press $\triangleleft/\triangle/\nabla/\triangleright$ to choose **No Smart key**, and then press **Save**.

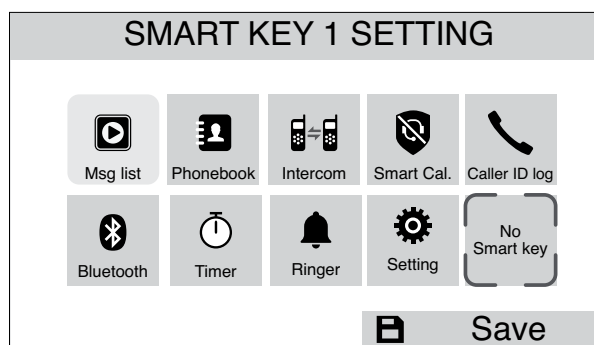

Bluetooth

Pair and connect your Bluetooth cellular phone or headset with the telephone base. Before you begin, make sure that you have cellular coverage and your Bluetooth enabled cell phone or handset is not connected to any other Bluetooth device.

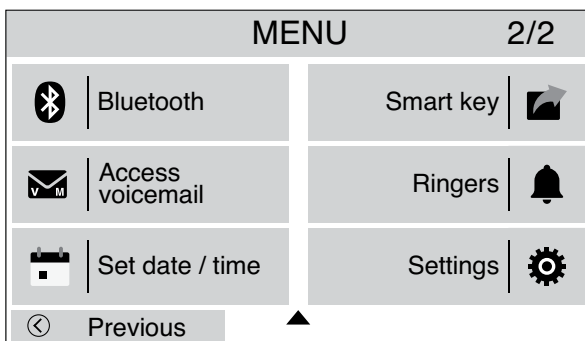

Add a Bluetooth cell phone/headset

1. Press **Menu** on the telephone base.
2. Press \triangle/∇ to scroll to the next page, and then select **Bluetooth**.

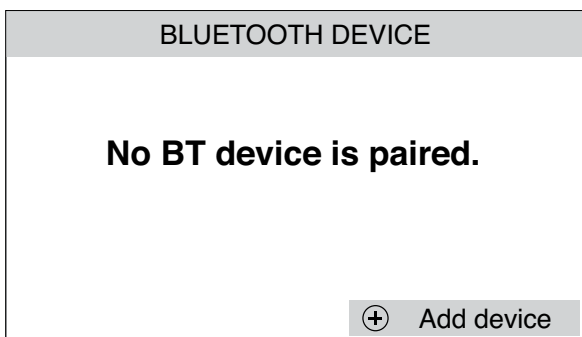

3. Press **+ Add device**.





4. Press **Add cellular**  or **Add headset** .

 - For cellular, go to **Cell phone**.
 - For headset, go to **Headset**.

Cell phone

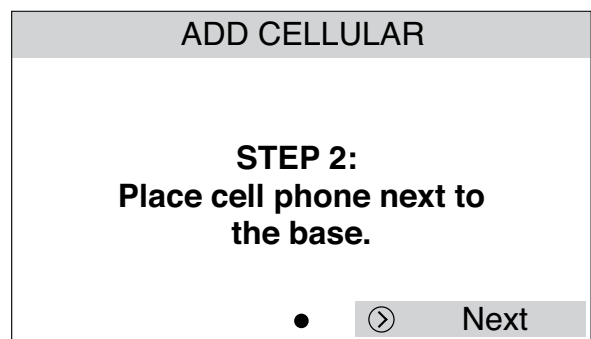
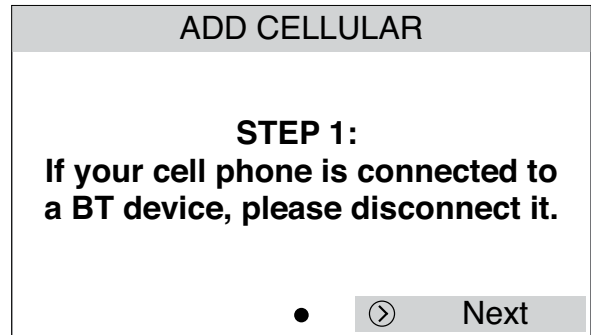
5. Follow the on-screen instructions and press **Next**.



6. Your telephone (**VTech DECT 6.0**) starts searching and pairing with your cell phone, press the appropriate key on your cell phone to continue the pairing process.
 - The **CELL 1 | CELL 2 HEADSET**  lights on the base flash while pairing.

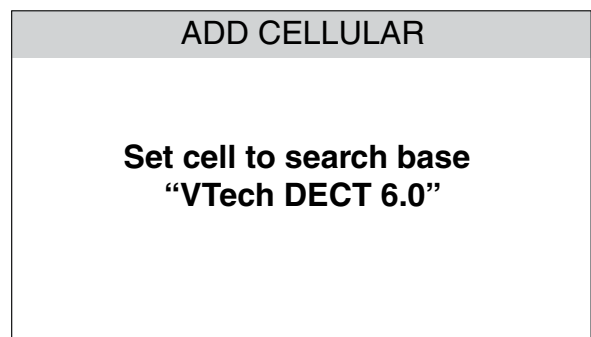

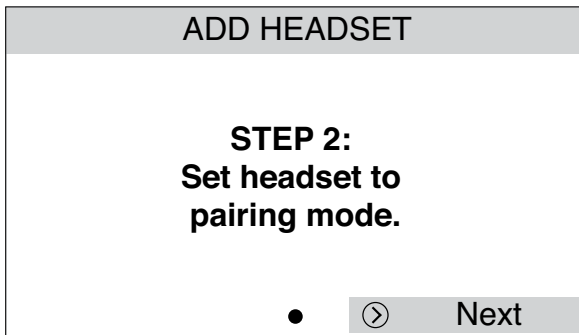
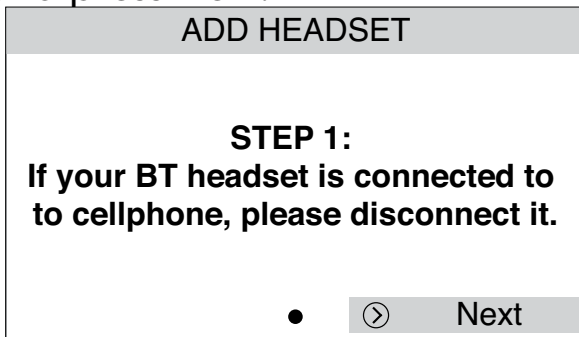

Headset

5. Follow the on-screen instructions and press Next.



6. Place your headset next to the base and start pairing.



Once your cell phones or headset are paired,  and/or  display on the base LCD screen.

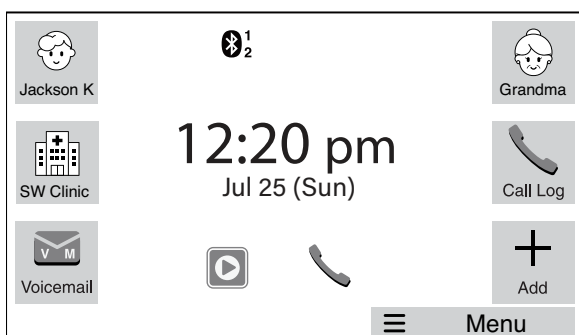

Download your cell phone phonebook using the base

NOTE

- Before downloading the phonebook, make sure cell phone is paired, active, and connected to the system.

1. Press **Menu** on the telephone base.
2. Press Δ/∇ to scroll to the next page, and then select  **Bluetooth**.

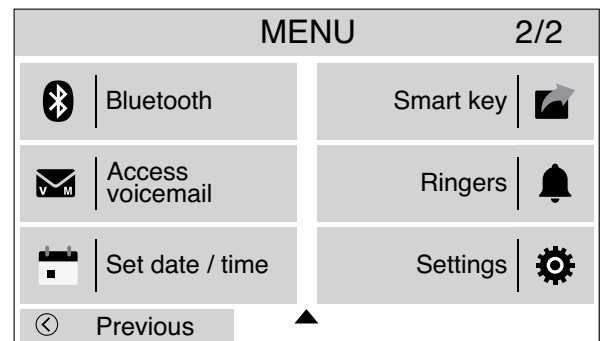

3. Press **Phonebook download**  smart key.

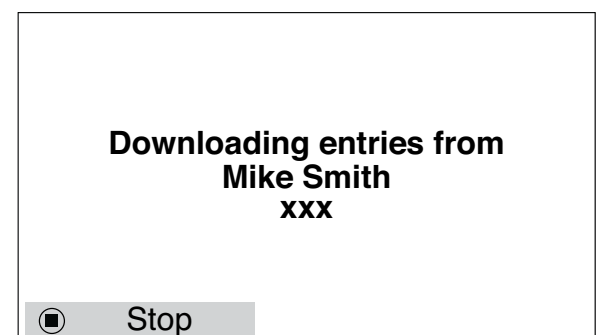
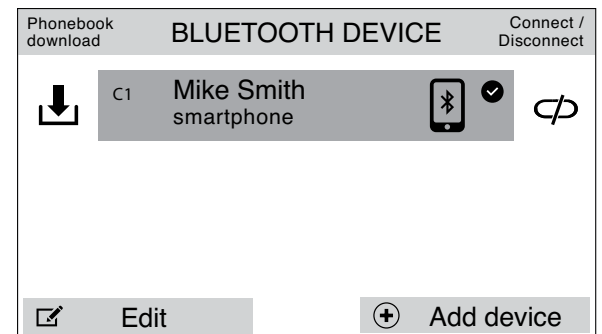

Once your Phonebook entries are added, the LCD screen displays:-



Disconnect/ Reconnect your Bluetooth device

1. Press **Menu** on the telephone base.
2. Press \triangle/∇ to scroll to the next page, and then select **Bluetooth**.
3. Press the respective smart key CP / CP **Connect/Disconnect** to disconnect and connect. **-OR-**

Press the softkey **Connect** to reconnect.

NOTE

- Make sure to switch on the Bluetooth function of your device if you need to reconnect.

Edit / remove your Bluetooth cell phone or headset

1. Press Menu on the telephone base.
2. Press \triangle/∇ to scroll to the next page, and then select **Bluetooth**.
3. Press **Edit**.

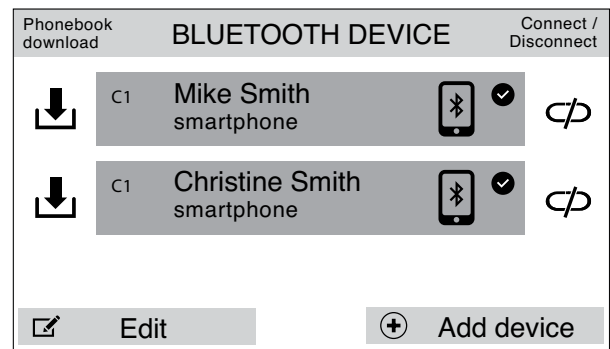

4. Press the respective smart key **X** to select and remove the bluetooth device, or press **Remove all** to delete all devices from the list.

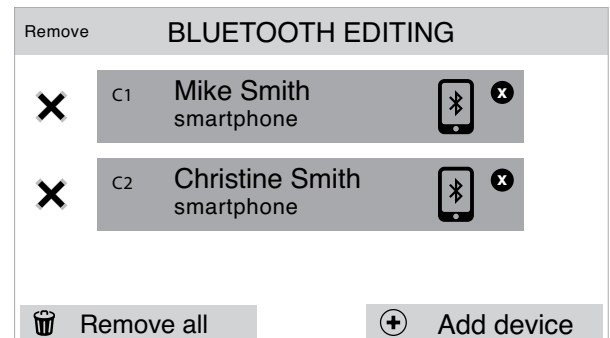

Auto Bluetooth connection

When an active device moves within Bluetooth range of the telephone base, or is turned on within range, the telephone base tries to connect to the device. When the device moves out of range, it is disconnected. Your device might make a connect or disconnect sound.

A connected device could also be disconnected by:

- Turning off the Bluetooth device.
- Turning off the Bluetooth feature of the device.

- The Bluetooth device is not within range of the telephone base.

2. Speak toward the base and wait for feedback.

Activate remove voice control

NOTE

- Make sure cell phone is paired, active, and connected to the system via Bluetooth.

Handset



1. Press .
 - You will hear the confirmation tone from handset via the cell phone's voice app.



2. Speak toward the handset and wait for feedback.



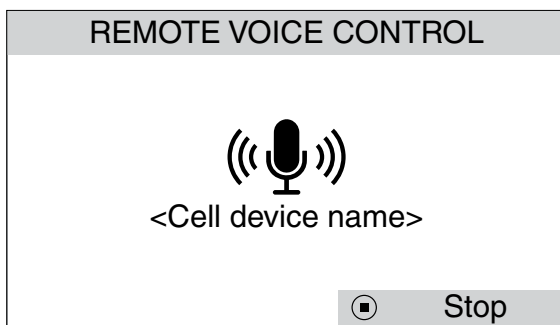

Base

1. Press .
 - You will hear the confirmation tone from handset via the cell phone's voice app.







Use phone menu

On the handset

1. Press  in idle mode (when the telephone is not in use) to enter the main menu.
2. Press  to scroll through menu items.
3. Press  to select or save the highlighted item.
Press  to cancel an operation, back up to the previous menu, or exit the menu display.

On the base







1. Press   **Menu** on the telephone base.
2. Press  to scroll to through menu items.
3. Press the respective  Smart key to select.
Press  to cancel an operation, back up to the previous menu, or exit the menu display.

Operate





Make, answer or end a cell call

Make sure you have pair your cell phone(s) to the telephone system. Go to **Add a Bluetooth cell phone/ headset.**



Make a cell call

1. Press  on the handset or  on the base.
 - If you have only one cell phone connected to the telephone base, press  to select the only device.
 - If you have two cell phones connected to the telephone, press / to select a cell phone and then press .
2. Enter the telephone number to dial.

Predial a cell call

1. Enter the telephone number.
2. Press  on the handset or  on the base to dial.
 - If you have only one cell phone connected to the telephone base, it is automatically selected to make cell calls.
 - If you have two cell phones connected to the telephone base, press / to select a cell phone and then press .



Answer a cell call

- Press  or  on the handset.
- Press  on the base.

End a cell call



- Press , or put the handset in the telephone base or charger.
- Press **End** on the base.

NOTES

- The handset displays **Unable to call** if your cell phone is in use.
- You can also use your cell phone to answer the call. If you answer with your cell phone, it disconnects from the telephone base.
- The screen shows the elapsed time as you talk (in hours, minutes and seconds).
- When predialing (preview numbers before dialing), press  on the handset to backspace and delete; press and hold  to insert a dialing pause (a **P** appears).

Make, answer, or end a home call



Make a home call

- Press  or  on the handset, and then enter the telephone number.
- Press  on the base, and then enter the telephone number.



Predial a home call

Enter the telephone number on the handset, then press  or  to dial.

Answer a home call

- Press  or  on the handset.
- Press  on the base.

End a home call

- Press  or put the handset in the telephone base or charger.
- Press **End** or  again on the base.



Using a Bluetooth headset to answer a home call

You can use a Bluetooth headset to answer home calls. However, you need to keep the device within 15 feet of the telephone base for optimal performance. Please see the user's manual of your Bluetooth headset for more information.

Answer or end a home call using a Bluetooth headset

Press the call key on your headset.

NOTES

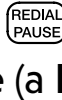



- The handset displays **Unable to call** if the telephone line is in use.
- The screen shows the elapsed time as you talk (in hours, minutes and seconds).
- **On the handset**
 - When predialing (preview numbers before dialing), press  to backspace and delete;  press and hold to insert a dialing pause (a **P** appears).
- **On the base**
 - When predialing (preview numbers before dialing), press **Backspace** to backspace and delete; press and hold  to insert a dialing pause (a **P** appears).

View dialing options

The incoming caller ID log entries have 10 digits (the area code plus the seven-digit number). You can add **1** in front of the telephone number before you dial in the caller ID log or store to the phonebook.

While reviewing the caller ID log, press **#** (pound key) or **1** repeatedly if you need to add or remove **1** in front of the telephone number before dialing or saving it in the phonebook.



When the number shows the correct format for dialing:

- Press  or  on the handset or press  on the base to call the number using the home line.
- Press  on the handset or  on the base to call the number using the cell line.

Option while on a call

When you are on a home or cell call and speaking to the caller, and you do not want to continue the call, you can press

 to end the call. The telephone plays the block announcement *"The number you are calling is not accepting your call. Please hang up."* to the caller, and the call will be terminated. The caller's number, if available, will be added to your block list.

- Press  on the handset or telephone base. The screen displays **Block and end?** and the caller's number, if available. Press  to end the call.



NOTE

- You can press  to end the call even if Smart call blocker is turned off.

Join a call

Join a call in progress

Another handset can join you on home call. The call continues until all parties hang up. You can share an outside call with up to two system devices.

- When a handset is already on a call, press  or  on another handset to join the call.
- Press  or place the handset in the telephone base or handset charger



to exit the call. The call continues on the other handset until both handsets hang up.

NOTE

- If you have paired a DECT 6.0 cordless headset or speakerphone to the telephone base, you can also join a call in progress using the paired device. Refer to the user's manuals of the respective product for more information.

Intercom

Initiate an intercom call on the handset

1. Press  on the handset in idle mode.
2. Press ▲/▼ to highlight **Intercom**, then press  .
 - The screen displays **Intercom to:**.
3. Use the dialing keys to enter a device number (1-5). The handset shows **Calling HS X**. The destination handset rings and shows **HS X is calling**.

Initiate an intercom call on the base

1. Press **Menu** and then press ◀/▶/▲/▼ to select **Intercom**  .
 - The base LCD screen displays **Calling Handset X ...**, while the handset screen displays **Base is Calling**.
 - Press **Cancel** to end the call.



Answer an intercom call

Press  or  . Both handsets now show **Intercom**.







End an intercom call

Press  or place the handset back in the telephone base or charger.

NOTES

- For cordless headsets and speakerphones, refer to the corresponding user's manual on how to answer and end an intercom call.
- You can cancel the intercom call before it is answered by pressing  on the handset.
- If you are calling all handsets, only the first handset to pick up can answer the intercom call.
- If the destination device does not answer the intercom call within 100 seconds, or if the device is in use, on a call, or out of range, the initiating device displays **Unable to call** and returns to idle mode.
- To temporarily silence the intercom ringer, press  or  on the destination handset/headset.
- You can only use one pair of devices at a time to make intercom calls.



Transfer a call via intercom

1. When on an outside call, press .
2. Press ▲/▼ to highlight **Intercom**, then press  to select.
 - The handset screen displays **Intercom to**.
3. Press  to select.
 - The call is automatically put on hold.
4. Your handset shows **Intercom to:**. Use the dialing keys to enter a handset number (**1-5**).
 - Your handset shows **Calling HS X**. The destination handset rings and shows **HS X is calling**.
5. To answer the intercom call on the other device, press , , or  on the destination handset.
 - The outside call is still on hold. Both handsets now show **Intercom**.
6. To transfer the call, press  or place the handset back in the telephone base or charger. The other handset automatically connects to the outside call.

NOTES

- If you want to cancel an intercom call and reconnect to the outside call before the destination handset answers, press  on the originating handset.

- If the called device does not answer the intercom call within 100 seconds, or if the device is in use, on a call or out of range, the calling handset shows **Unable to call** and returns to the outside call.

- You can press  or  on the destination handset to temporarily silence the intercom ringer.
- Only one intercom call can be established at a time.

Sound

Use speakerphone

During a call, press  to switch between the speakerphone and normal handset use.

To hand up, press  or return the handset to the telephone base or charger.

Mute the microphone

Use the mute function to turn off the microphone. You can hear the caller, but the caller cannot hear you.

To mute a call

While on a call, press  on the handset. The screen displays **Muted** until the mute function is turned off.

To end mute a call

Press  on the handset again and resume speaking. The screen briefly

displays **Microphone on**.

Mute is automatically cancelled when you end the call.

Temporary ringer silencing

When the telephone is ringing, you can temporarily silence the ringer of the handset without disconnecting the call. The next call rings normally at the preset volume.

To silence the handset ringer

Press  or  on the handset. The handset screen shows **Ringer muted**.

Find handset

Page/ find handset

This feature helps you find all system handsets.

To start paging

Press  on the telephone base when it is not in use.

- All idle handsets ring and display **** Paging ****.
- The base LCD displays **Paging all devices**.

To end paging

- Press , , ,  on the handset ;
- Press  again on the telephone base;
- Press  on the telephone base;

- Press **Stop** on the telephone base;
- or -
- Place the handset in the telephone base or charger.

NOTES













- If you press  on a handset, the ringer of that handset is silenced but the paging tone continues on the other handsets.
- If a handset is accessing the answering system, on a call (intercom call or outside call), or out of range, that handset does not beep when paged.
- You cannot use the find handset feature while the telephone base is playing messages or the answering system is being accessed remotely.

Phonebook |









Phonebook entry

The phonebook can store up to 1,200 entries, which are shared by all handsets and the telephone base. Each entry may consist of a telephone number up to 30 digits, and a name up to 15 characters.





Add a phonebook entry with a handset

1. Press  on the handset in idle mode.
2. Press  to highlight **Phonebook**, then press .
3. Press  to select **Add new entry**.
4. Press  to proceed to entering number.
 - The screen shows **Enter number**.
5. Use the dialing keys to enter a telephone number (up to 30 digits).
 - Press  to move the cursor to the left or right.
 - Press  on the handset to erase a digit.
 - Press and hold  on the handset to erase all digits.
 - Press and hold  to insert a three-second dialing pause (a **P** appears). **-OR-** Press  to copy a number from the redial list. Press , or press  repeatedly to

locate the desired number.

- Press  to confirm.
6. Press  and enter the name, and then press 
 - The screen shows **Enter name**.
 7. Use the dialing keys to enter a name (up to 15 characters) when prompted.
 - Press a key repeatedly until the desired character shows on the screen.
 - Press  to move the cursor to the left or right.
 - Press **0** to add a space.
 - Press  on the handset to erase a character.
 - Press and hold  on the handset to erase all characters.
 - Press  to change the next letter to upper or lowercase.
 8. Press  to store your new phonebook entry.
 - The screen shows **Saving...** and then **Saved** with confirmation tone.

Add a phonebook entry with base

1. Press **Menu** and then  on the telephone base if you have added **Phonebook**  as Smart key. **-OR-** Press the phonebook smart key  | **Phonebook**. **-OR-** Press  on the telephone base.

- The screen shows **Phonebook is empty. Add a contact?**. Press **Yes**.

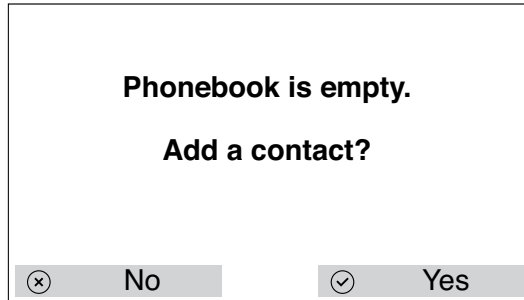

2. Use the dialing keys to enter a telephone number (up to 30 digits).

- Press \leftarrow/\rightarrow to move the cursor to the left or right.
- Press **Backspace** to erase a digit.
- Press and hold **Backspace** to erase all digits.
- Press and hold **REDIAL PAUSE** to insert a three-second dialing pause (a **P** appears). **-OR-** Press **REDIAL PAUSE** to copy a number from the redial list. Press \triangle/∇ , or press **REDIAL PAUSE** repeatedly to locate the desired number.

3. Press **Next** to proceed to entering name.

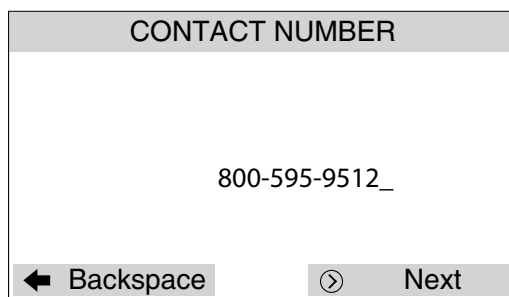

4. Use the dialing keys to enter a name (up to 15 characters) when prompted.

- Press a key repeatedly until the desired character shows on the screen.
- Press \leftarrow/\rightarrow to move the cursor to the

left or right.

- Press **0** to add a space.
- Press **Backspace** to erase a character.
- Press and hold **Backspace** to erase all characters.
- Press **a X A TONE** to change the next letter to upper or lowercase.
- Press **CANCEL** to return to previous page.

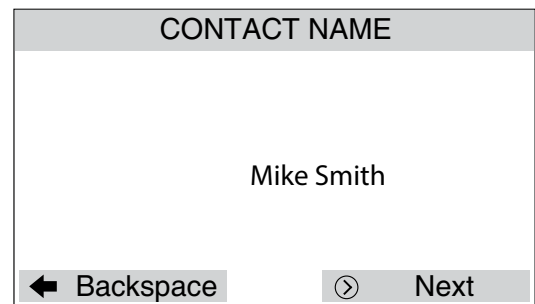

5. Press **Next** to proceed to selecting **Profile Picture**.

6. Press $\leftarrow/\triangle/\nabla/\rightarrow$ to select the desired picture, and press **Select** to confirm.

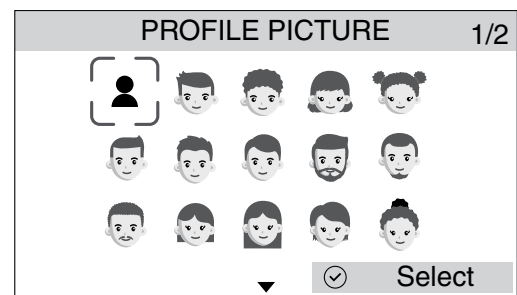

7. Press $\leftarrow/\triangle/\nabla/\rightarrow$ to select the desired color, and press **Select** to confirm.

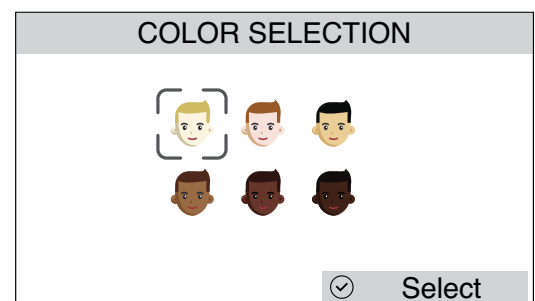





- The screen preview your entry.
- Press **Save** to confirm entry.







Review the phonebook entries with a handset

NOTE

- Only one handset or the telephone base can review the phonebook at time. If another handset tries to enter the phonebook, caller ID log or call block list, it shows **Not available**.

1. Press  when in idle mode.
 - The screen shows the first entry.
2. Press  to browse through the phonebook or use the dialing keys to start a name search.



-OR-

1. Press  when in idle mode.
2. Press  to scroll to **Phonebook**, then press .
3. Press  to scroll to **Review**, then press .
 - The screen shows the total number of entries, and then the first entry in the phonebook.
4. Press  to scroll to browse through the phonebook.
 - Entries appear alphabetically by the first letter in the name.



Review the phonebook entries with base

There are 3 ways to access and review.



Option 1

1. Press  on the telephone base.
2. Press  to browse the entries.

Option 2

If you have set up phonebook smart key , you can press it and  to browse the entries.

Option 3

1. Press **Menu** and then  to go to Phonebook menu option.
2. Press  to browse the entries.

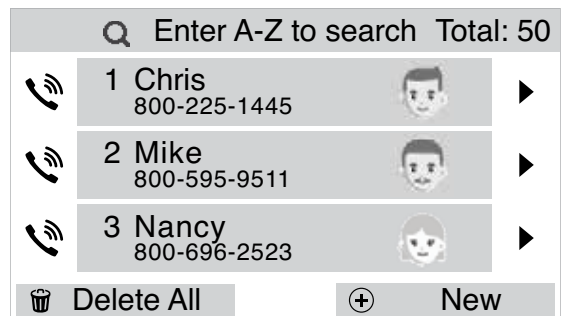

Dial a phonebook entry with a handset

You can dial a phonebook entry on either a home or cell line.

1. Search for the desired entry in the phonebook (see **Review the**

phonebook entries with a handset | Review the phonebook entries with base or Alphabetical search with a handset).

2. When the displayed number is in the



correct format, press  or  on the handset to dial with the home line. **-OR-**

Press  on the handset to dial with the cell line.



Dial a phonebook entry with base

There are 2 ways to dial.

Option 1



1. Press  and Δ/∇ to scroll to your desired entry. Then, press  smart key next to your desired entry to dial.

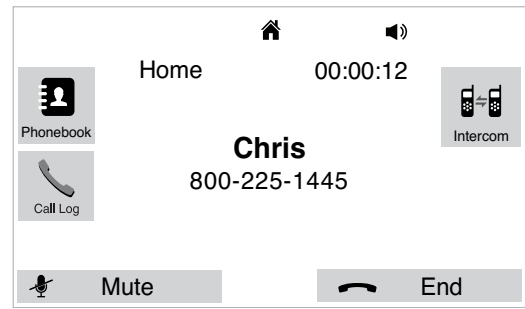

2. While calling, you can press  **Mute** to mute, or press  **End** to end the call when you are done.



Option 2

1. Press  on the telephone base.
 2. Press Δ/∇ to scroll to your desired entry, and then press  smart key to select the entry.

3. Press  or  on the base to dial. **-OR-**
 Press **Dial**.

Delete a phonebook entry with a handset

NOTE

- Once deleted, you cannot retrieve that entry.

1. While reviewing a phonebook entry (see **Review the phonebook entries with a handset** or **Alphabetical search**





with a handset), press  **MUTE DELETE**.

- The screen shows **Delete entry?**

2. Press  to delete the displayed entry from the phonebook.

- The handset shows **Deleting...** and then you hear a confirmation tone.

Delete all phonebook entries with a handset

1. Press  on the handset when in idle mode.
2. Press ▲/▼ to scroll to **Phonebook**, then press .
3. Press ▲/▼ to scroll to **Delete all**, then press 
 - The handset shows **Delete all?**.
4. Press  to confirm.
 - The handset shows **Deleting....**
You hear a confirmation tone.









Delete a phonebook entry with base



1. While reviewing a phonebook entry (see **Review the phonebook entries**), press ►  smart key to select the entry.
2. Press **Delete X**.
 - The screen shows **Delete Contact?**
3. Press **Yes** to confirm.

Delete all phonebook entries with base



1. While reviewing a phonebook entry (see **Review the phonebook entries with base**), press **Delete all**.
 - The screen shows **Delete all contact?**
2. Press **Yes** to confirm.
 - The handset shows **Deleted** and then you hear a confirmation tone.

Edit a phonebook entry with a handset

1. While reviewing a phonebook entry (see **Review the phonebook entries with a handset**), and press 
 - The screen shows the total number of entries and the current entry.
2. Press ▲/▼ to select the entry you want to edit.
3. Use the dialing keys to edit the number (up to 30 digits).
 - Press ▲/▼ to move the cursor to the left or right.
 - Press and hold  to insert a three-second dialing pause (a **P** appears).
 - Press  on the handset to erase a digit.
 - Press and hold  on the handset to erase all digits.
 - Press and hold  to copy a number from the redial list and then ▲/▼, or pressing  repeatedly to locate the desired number.
 - Press  to confirm.
4. Press  to save the number.
 - The screen shows **Enter name** briefly and then the current name of the entry.



5. Edit the characters.
 - Press **0** to add a space.
 - Press **▲/▼** to move the cursor to the left or right.
 - Press  on the handset to erase a character.
 - Press and hold  on the handset to erase all characters.
6. Press  to save.
 - The handset shows the updated entry.

Edit a phonebook entry with base

1. While reviewing a phonebook entry (see **Review the phonebook entries with base**), press **▶**  smart key to select the entry.
2. Press **Edit** .





3. Use the dialing keys to enter a telephone number (up to 30 digits).
 - Press **◀/▶** to move the cursor to the left or right.
 - Press **Backspace** to erase a digit.
 - Press and hold **Backspace** to erase all digits.
 - Press and hold  to insert a three-second dialing pause (a **P**

appears). **-OR-** Press  to copy a number from the redial list. Press **▲/▼**, or press  repeatedly to locate the desired number.

4. Press **Next** to proceed to entering name.



5. Use the dialing keys to enter a name (up to 15 characters) when prompted.
 - Press a key repeatedly until the desired character shows on the screen.
 - Press **◀/▶** to move the cursor to the left or right.
 - Press **0** to add a space.
 - Press **Backspace** to erase a character.
 - Press and hold **Backspace** to erase all characters.
 - Press  to change the next letter to upper or lowercase.
 - Press  to return to previous page.
6. Press **Next** to proceed to selecting **Profile Picture**.

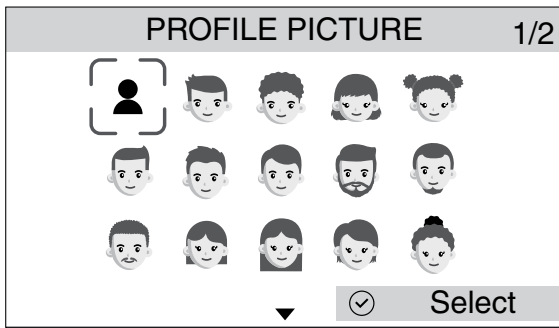

7. Press $\triangleleft/\triangle/\triangleright/\triangleright$ to select the desired picture, and press **Select** to confirm.

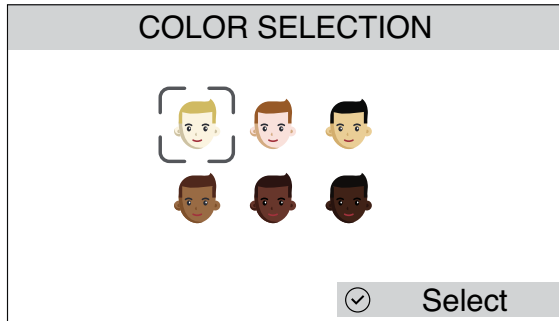

8. Press $\triangleleft/\triangle/\triangleright/\triangleright$ to select a preferred color, and press **Select** to confirm.
 - The screen preview your entry.
 - Press **Edit** to re-edit or **Save** to confirm entry.

Alphabetical search with a handset

You can use the enhanced 3-character search to find your contacts quickly and efficiently.

1. Press \blacktriangle when the handset is in idle mode.
2. When an entry appears, use the dialing keys (**0-9**) to start a name search (alphabetical search).

For example, if you have the names Jennifer, Jessie, Kevin and Linda in your phonebook:

- If you press **5 (JKL)** once, **J** and then Jennifer displays.

- If you press **5 (JKL)** once, **J** displays. Press \blacktriangledown . **Jessie** displays.
- If you press **5 (JKL)** twice, **K** and then **Kevin** displays.
- If you press **5 (JKL)** three times, **L** and then **Linda** displays.
- If you press **5 (JKL)** four times, **5** displays.
- If you press **5 (JKL)** five times, **J** displays and then **Jennifer** displays again.

Alphabetical search with base









1. Press  on the telephone base.
2. Use the dialing keys (**0-9**) to start a name search (alphabetical search).

NOTE







- The phonebook shows the first name beginning with the first letter associated with the dialing key, i.e. if there is an entry in the phonebook that begins with that letter.
- If you press a dialing key (**0-9**) and no name starts with any letter on that key, the phonebook shows the entry that matches the next letter in the phonebook.
- Press $\blacktriangle/\blacktriangledown$ (handset) or \triangle/\triangleright (base) to scroll through the entries beginning with that letter.
- To see other names that start with the letters on the same dialing key, keep pressing the key until the desired letter is shown.
 - The names appear in alphabetical order.

Redial list

Dial a redial list entry with a handset

1. Press  to enter the redial list.
2. Press ,  or  repeatedly to browse until the desired entry displays.
 - When the desired redial entry displays, press  or  to dial using the home line, or press  to dial using the cell line.
3. Press  to dial the displayed number.

Dial a redial list entry with base

1. Press  to enter the redial list.
2. Press ,  or  repeatedly to browse until the desired entry displays. The base beeps twice at the end of the list.
 - When the desired redial entry displays, press  to dial using the home line, or press  to dial using the cell line.





Review a redial list entry with a handset

1. Press  in idle mode.
2. Press ,  or  repeatedly to





browse until the desired number displays. The handset beeps twice at the end of the list.

3. Press  on the handset to exit.



Review a redial list entry with base

1. Press  to enter the redial list.
2. Press ,  to browse until the desired entry displays. The base beeps twice at the end of the list.
3. Press  on the base to exit.

Delete a redial list entry with a handset

1. Press  in idle mode.
2. Press ,  or  repeatedly to browse until the desired number displays.
3. Press  on the handset to delete the displayed number.
 - You hear a confirmation tone.



Delete a redial list entry with base

1. Press  to enter the redial list.
2. Press ,  to browse until the desired entry displays. The base beeps twice at the end of the list.
3. Press **Delete** on the base to delete.

Call waiting

Call waiting on the cell line

If you subscribe to call waiting service from your cell phone service provider, and someone calls while you are already on a call on the cell line, the handset flashes , and you hear a beep.

- Press  on the handset to put your current call on hold and take the new call.
- Press  on the handset at any time to switch back and forth between calls.



NOTES

- If the Smart call blocker feature is on and in screening mode, and you receive a call waiting cell call while you have already picked up a screened home call:
 - The telephone checks whether the call waiting cell call's number can be found in the block list. If yes, the telephone displays **Blocked call** and rejects the call.
- The screening feature of Smart call blocker is applicable to home calls only.

Call waiting on the home line



If you subscribe to call waiting service from your telephone service provider, and someone calls while you are already on a call on the home line, you hear two beeps.

If you subscribe to call waiting service from your telephone service provider, and someone calls while you are already on a call on the home line, the handset flashes , and you hear a beep.

1. Press  on the handset to put your current call on hold and take the new call.
2. Press  on the handset at any time to switch back and forth between calls.

NOTES

If the Smart call blocker feature is on and in screening mode, and you receive a call waiting home call while you have already picked up a screened home call:

- The telephone checks whether the call waiting call's number can be found in the phonebook, block list, or allow list. It also check whether the caller name is in the star name list.
 - After that, the telephone displays the caller ID information or **Blocked call** accordingly.
- You can press  or  to take the new call.
- If the telephone is screening a home call, the call waiting call will be ignored and logged as missed call in the caller ID log.
- The screening feature of Smart call blocker is applicable to home calls only.





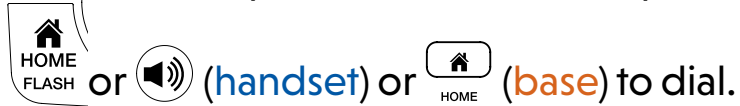

Predial via home call and cell call

Predial a home call



Enter the telephone number, then press



Predial a cell call

1. Enter the telephone number.
2. Press  (handset) or  (base) to dial.
 - If you have only one cell phone connected to the telephone base, it is automatically selected to make cell calls.
 - If you have two cell phones connected to the telephone base, the handset displays **Select a device**. Press / (handset) or / (base) to select a cell phone and then press  or **Select** respectively.

NOTE





- When predialing (preview numbers before dialing), press  (handset) or **Backspace** (base) to backspace and delete; press and hold  (handset) or  (base) to insert a dialing pause (a **P** appears).

Chain dialing



Use this feature to initiate a dialing sequence from numbers stored in the phonebook, caller ID log or redial list while you are on a call.

Chain dialing is useful if you wish to access other numbers (such as bank account numbers or access codes) from the phonebook, caller ID log or redial list.





Access a number in the phonebook with a handset while on a call

1. Press .
2. Press  to select **Phonebook**.
3. Press / to scroll to the desired entry or perform an alphabetical search, and then press  to dial the displayed number.



Access a number in the phonebook with base while on a call

1. Press **Phonebook** .
2. Press / on the base to scroll to the desired entry or perform an alphabetical search, and then press **Dial** to dial the displayed number.





Access a number in the caller ID log with a handset while on a call

1. Press .
2. Press  to scroll to **Caller ID log**, then press .
3. Press  to scroll to the desired entry, and then press  to dial the displayed number.



Access a number in the caller ID log with base while on a call

1. Press **Call log** .
2. Press  to scroll to the desired entry, and then press **Dial** to dial the displayed number.

Access the redial list with a handset while on a call



1. Press .
2. Press  or  until the desired number displays.
3. Press  to dial the displayed number.

Access the redial list with base while on a call

1. Press .
2. Press  or  until the desired number displays.
3. Press **Dial** to dial the displayed number.



NOTES

- You cannot edit a phonebook entry while on a call.
- You cannot copy a caller ID log entry into the phonebook while on a call.
- You can only view the numbers in the phonebook, caller ID log or redial list while on a call and cannot edit, delete or save entries.
- Press  (handset) or  (base) to exit redial list, phonebook or caller ID log while on a call.

Caller ID

If you subscribe to caller ID service, information about each caller appears after the first or second ring. The caller ID log stores up to 50 entries. Each entry has up to 24 digits for the phone number and 15 characters for the name.

Handset

Review the caller ID log entry



Review the caller ID log to find out who called, to return the call or to copy the caller's name and number into your phonebook.

NOTE

- Only one handset or the telephone base can review the caller ID log at time. If another handset tries to enter the phonebook, caller ID log or call block list, it shows **Not available**.

1. When a handset is in idle mode, press  to view the caller ID log in reverse chronological order starting with the most recent call.



-OR-

You can also review the caller ID log by pressing  in idle mode, then press  to scroll to **Caller ID log**. Press  twice to select **Review**.

2. Press  to scroll through the list. The handset beeps twice when you reach the beginning or end of the caller ID log.

3. Press  to exit the caller ID log.



Save a caller ID log entry to the phonebook

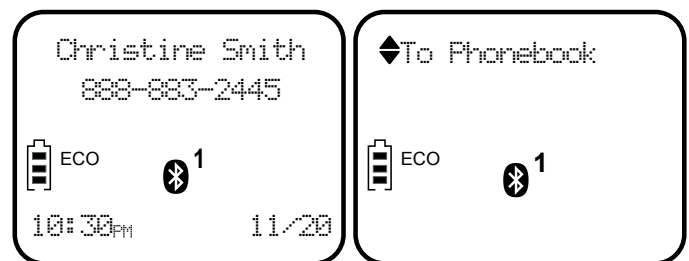





1. Press  to review the caller ID log.
2. Press  to browse through the caller ID log.
3. When the desired entry displays, press .





4. Press  again to choose **To Phonebook**.
5. When the screen shows **Enter number**, use the dialing keys to modify the telephone number (up to 30 digits).



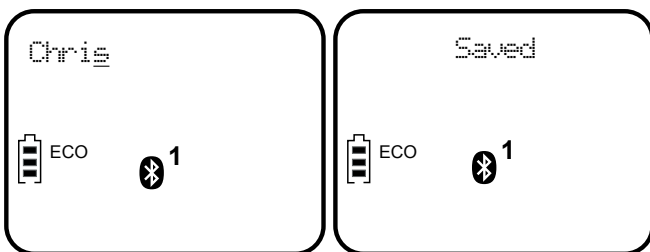

- Press  (handset) to move the cursor to the left or right.
- Press and hold  to enter a 3-second dialing pause (a **P** appears).













- Press  to erase a digit.
 - Press and hold  to erase all digits.
6. Press  to save the number in the display.
 - The screen shows **Enter name**.
 7. Use the dialing keys to modify the name (up to 15 characters).
 - Press **0** to add a space.
 - Press  to move the cursor to the left or right.
 - Press  to erase a character.
 - Press and hold  to erase all characters.
 - Press  to change the next letter to upper or lowercase.









8. Press  to save.
 - You hear a confirmation tone.

Save a caller ID log entry to the block list

1. Press  to review the caller ID log.
2. Press  to browse through the caller ID log.
3. When the desired entry displays,

- press .
4. Press  to scroll to **To Block list**, then press .
 5. The handset displays **Enter number**. Use the dialing keys to edit the number, when necessary.
 - Press  to move the cursor to the left or right.
 - Press  to backspace and erase a digit.
 - Press and hold  to erase the entire entry.
 - Press and hold  to enter a 3-second dialing pause (a **P** appears).
 6. Press  to move to the name.
 - The screen shows **Enter name**.
 7. Use the dialing keys to add or edit the name.
 - Press  to move the cursor to the left or right.
 - Press **0** to add a space.
 - Press  on the handset to erase a character.
 - Press and hold  on the handset to erase all characters.
 - Press  to change the next letter to upper or lowercase.
 8. Press  to save.

Save a caller ID log entry to the star name list







1. Press  to review the caller ID log.
2. Press  to browse through the caller ID log.
3. When the desired entry displays, press .
4. Press  to scroll to **To Star name**, then press .
 - The screen displays **Star the name?**.
5. Press  to confirm.

Delete caller ID log entries

To delete an entry

1. Search for the desired entry in the caller ID log (see **Review the caller ID log entry**).
2. When the desired entry is displayed, press  on the handset.
 - You hear a confirmation tone.

To delete all entries





1. Press  on the handset in idle mode.
2. Press  to highlight **Caller ID log**, then press .
3. Press  to highlight **Delete all**, then press .
4. When the screen shows **Delete all?**, press  to confirm.

- The screen displays **Deleting....**
- There is a confirmation tone and the screen returns to the previous menu.



Base





Review the caller ID log entry

1. Press .
2. Press  to browse the entries.

CALLER ID LOG		Total: 3
	1 Walter 888-4544-5386	JAN 19 12:00pm
	2 Amy 800-4225-5386	JAN 25 10:00pm
	3 Sally 800-1112-5386	JAN 27 12:00pm
	Edit	

Save a caller ID log entry to the phonebook



1. Press  to review the caller ID log.
2. Press  to browse through the caller ID log.
3. When the desired entry displays, press its  smart key.

CALLER ID LOG		Total: 3
	1 Walter 888-4544-5386	JAN 19 12:00pm
	2 Amy 800-4225-5386	JAN 25 10:00pm
	3 Sally 800-1112-5386	JAN 27 12:00pm
	Edit	

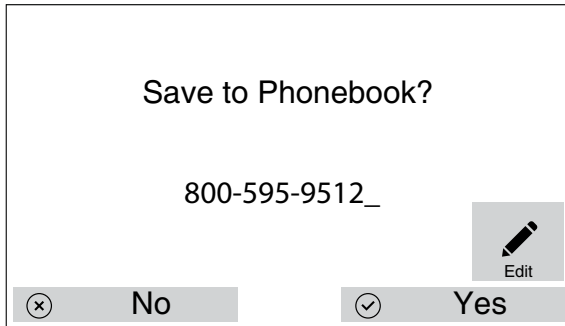
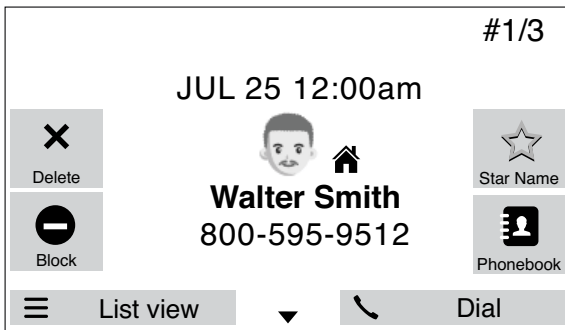
4. On the entry page, press Phonebook .



5. Press **YES** to save the telephone number to the Phonebook. You can also edit the number if needed.

1. Press the smart key **Edit** .
2. Use the dialing keys to modify the telephone number (up to 30 digits).
 - Press $\triangleleft/\triangleright$ to move the cursor to the left or right.
 - Press and hold  to enter a 3-second dialing pause (a **P** appears).
 - Press **Backspace** to erase a digit.
 - Press and hold **Backspace** to erase all digits.

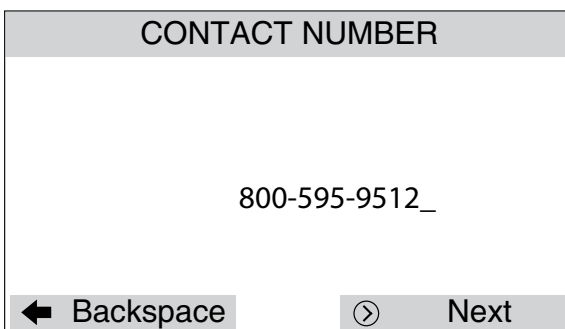

3. Press **Next**, and then enter contact name with dialing keys.



4. Press **Next**, and then use $\triangleleft/\triangle/\triangleright/\triangleright$ to select profile picture, and then press **Select**.

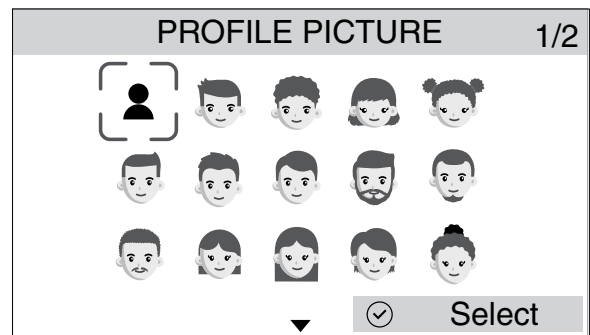

5. Press $\triangleleft/\triangle/\triangleright/\triangleright$ to select a preferred color, and then press **Select**.

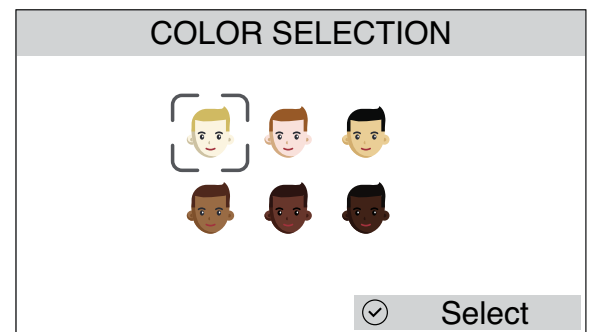

6. Press **Save** to save at **Preview**.

NOTES

- The screen shows **Number repeated** if the number is already in the phonebook. You cannot save the same number more than once.
- If you try to save a caller ID log entry to the phonebook without a number, the handset sounds an error tone.
- If the telephone number has more than 15 digits, only the last 15 digits

appear in the caller ID log. However, the telephone can still save all digits (up to 24 digits) of that telephone number from the caller ID log in the phonebook.

- You might need to change how a caller ID number is saved in the phonebook if the entry does not appear in the correct format. Caller ID numbers might appear with an area code that is not necessary for local calls, or without a 1 that is necessary for long distance calls.

Save a caller ID log entry to the block list

- Press **CID** to review the caller ID log.
- Press \triangle/∇ to browse through the caller ID log.
- When the desired entry displays, press its \blacktriangleright smart key.

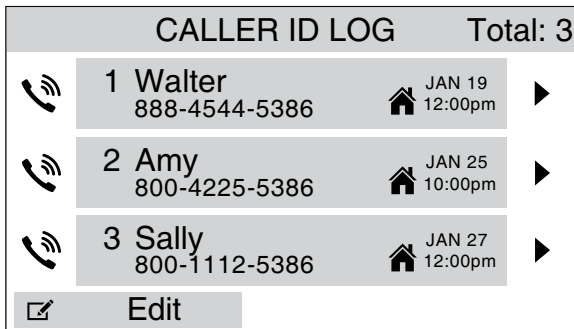

- On the entry page, press **Block**.

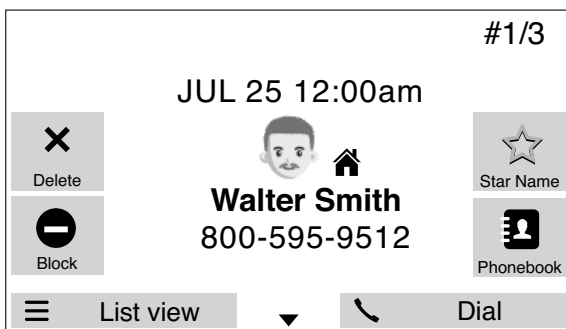

- Press **YES** to save the telephone number to the Block list. You can also edit the number if needed.

- Press the smart key **Edit**.
- Use the dialing keys to modify the telephone number (up to 30 digits).
 - Press \triangle/∇ to move the cursor to the left or right.
 - Press and hold **REDIAL PAUSE** to enter a 3-second dialing pause (a **P** appears).
 - Press **Backspace** to erase a digit.
 - Press and hold **Backspace** to erase all digits.
- Press **Next**, and then enter contact name with dialing keys.
- Press **Next**, and then use \triangle/∇ to select profile picture, and then press **Select**.
- Press \triangle/∇ to select a preferred color, and then press **Select**.
- Press **Save** to confirm.

Save a caller ID log entry to the star name list

- Press **CID** to review the caller ID log.
- Press \triangle/∇ to browse through the caller ID log.
- When the desired entry displays, press its \blacktriangleright smart key.

CALLER ID LOG		Total: 3
	1 Walter 888-4544-5386	JAN 19 12:00pm
	2 Amy 800-4225-5386	JAN 25 10:00pm
	3 Sally 800-1112-5386	JAN 27 12:00pm
	Edit	

- On the entry page, press **Star Name**.

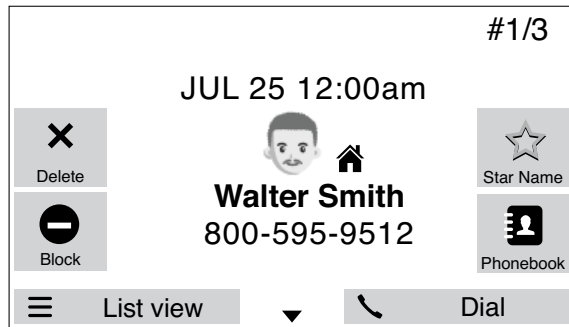

- Press **YES** to save the telephone number to the Star name list. You can also edit the number if needed.

- Press the smart key **Edit** .
- Use the dialing keys to modify the telephone number (up to 30 digits).
 - Press to move the cursor to the left or right.
 - Press and hold **REDIAL PAUSE** to enter a 3-second dialing pause (a **P** appears).
 - Press **Backspace** to erase a digit.
 - Press and hold **Backspace** to erase all digits.
- Press **Next**, and then enter contact name with dialing keys.
- Press **Next**, and then use to select profile picture, and then press **Select**.
- Press to select a preferred

color, and then press **Select**.

- Press **Save** to confirm.

Dial a caller ID log entry

- Search for the desired entry in the caller ID log (see **Review the caller ID log entry with a handset** | **Review the caller ID log entry**).

- When the desired entry is displayed, you can:

- Press or (**handset**) or (**base**) on the base to dial with the home line. - **OR** -
- Press (**handset**) or (**base**) to dial with the cell line.

Caller ID memory match

If the incoming telephone number matches the last 7 digits of a telephone number in your phonebook, the name that appears on the screen matches the corresponding name in your phonebook.

For example, if **Christine Smith** calls, her name appears as **Chris** if this is how you entered it into your phonebook.

NOTE

- The number you see on your caller ID is in the format sent by the telephone service provider. It usually delivers 10-digit telephone numbers (area code plus telephone number). If the

last 7 digits of the incoming telephone number do not match a number in your phonebook, the name appears as it is delivered by the telephone service provider.

Missed call indicator

When a cordless handset or the telephone base is in idle mode and has new or missed calls, its screen shows **XX Missed calls**.

All new and missed entries are counted as missed calls. Each time you review a new caller ID log entry (indicated by *NEW* on the screen), the missed calls message goes away. When there is a new unanswered call, the missed calls message displays again. The number of missed calls includes all new and missed entries that have not been reviewed.

If you do not want to review the missed calls one by one, but still want to keep them in the caller ID log, you can press

and hold  on the handset for four seconds when the handset is idle.

- You will hear a confirmation tone.
- All the entries in the caller ID log become old (reviewed already).
- Missed calls message disappears.

Set CID time sync

You can adjust the global clock to synchronize with the time from the incoming Caller ID with the base.

1. Press **Menu** →  → **Settings** .

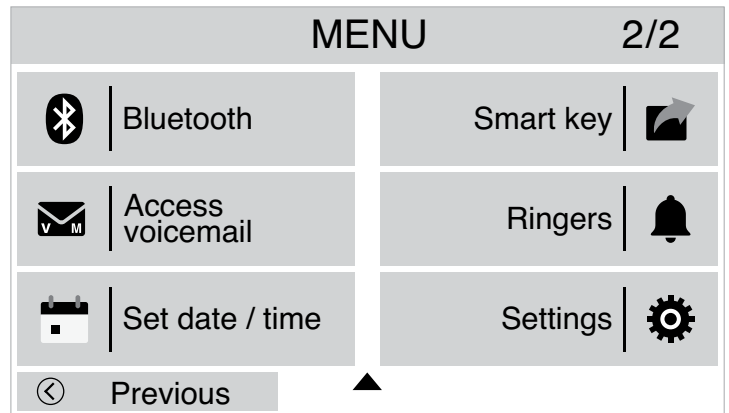









2. Press  **CID time sync.** → **Turn ON** / **Turn OFF.**

Answering system

About the built-in answering system and voicemail service

Your telephone has separate indicators for two different types of voice messages: those recorded on its built-in digital answering system and those recorded in your telephone service provider's voicemail (fees may apply). Your telephone's built-in digital answering system messages and voicemail messages are separate.

Built-in answering system VS voicemail service

Category	Built-in answering system 	Voicemail from telephone service 
Support by	Telephone system	Telephone service provider
Subscription	No	Yes
Fees	No	May apply
Answer incoming calls	<ul style="list-style-type: none"> After 4 rings by default; It can be changed in the handset or the telephone base menu. 	<ul style="list-style-type: none"> Usually after 2 rings; It can be changed by contacting your telephone service provider.
Storage	Messages are stored in the telephone base.	Messages are stored in a server or system provided by your telephone service.
	<p>Your messages will not be deleted automatically.</p> <p>You have to delete your messages manually.</p>	<p>Your messages may be automatically deleted after a period of time.</p> <p>Contact your telephone service provider for more details.</p>
Display new messages	<ul style="list-style-type: none"> Handset - XX new messages; Telephone base  2 	<ul style="list-style-type: none"> Handset  Telephone base 
Method to retrieve messages	<ul style="list-style-type: none"> Press  on the telephone base; Press  on the handset, and then select Play messages; -OR- Access remotely with an access code. 	<ul style="list-style-type: none"> Press and hold  on the dialpad, and enter an access number from your telephone service provider or dial to access voicemail.

Use your built-in answering system

New message indication

If **XX new messages** display on the handsets or  **2** display on the base, there are new messages in the built-in answering system. The system recording time is about 41 minutes in total, including the announcement.

Message window display	Description
0	There are no messages in the answering system.
0 (flashing)	After a power failure, the number in the message window flashes to indicate that the date and time need to be set.
1-99	<ul style="list-style-type: none"> Total number of messages and memos. Current message number during old message playback.
1-99 (flashing)	<ul style="list-style-type: none"> Total number of new messages and memos. The number flashes when there are new messages that have not been reviewed. Current message number during new message playback. After a power failure, the number in the message window flashes to indicate that the date and time need to be set.
1-99 & F (alternating)	Memory is full. Messages must be deleted before new messages can be recorded.



Message window display	Description
--	<ul style="list-style-type: none"> The answering system is being programmed by a system handset. The answering system is answering a call or recording a memo or announcement. The answering system is being accessed remotely. The phonebook or caller ID log is being accessed by a system handset.
0-6 bars	Telephone base ringer volume while adjusting. You can set up the Ringers for All lines, Cell lines (x2), and Home line.
1-6 bars	Speaker volume level of the handset while adjusting.



Turn on or off the answering system

If you turn the answering system on, it answers calls and records messages only on the home line. If your paired cell phone has voicemail, callers can leave messages with that voicemail service.

If your answering system is turned off and you change any of its settings, the answering system automatically turns on again.

Handset

1. Press  in idle mode.
2. Press  to highlight **Answering sys**, then press .

3. Press ▲/▼ to highlight **Answer on/off**, then press .
4. Press ▲/▼ to highlight **On** or **Off**, then press  to save.



Base

Press  to turn the answering system on or off.



Set number of rings

You can set your answering system to answer calls at least two rings earlier than your voicemail service. For example, if your voicemail service answers after six rings, set your answering system to answer after four rings. Thus, if you are on a call, or if the answering system is busy recording a message and you receive another call, the second caller can leave a voicemail message.

Handset

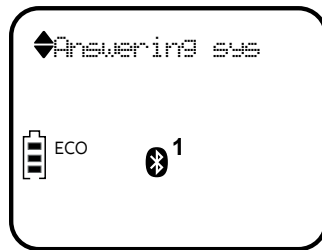
1. Press  in idle mode.
2. Press ▲/▼ to scroll to **Answering sys**, and then press .



3. Press  and select **Ans sys setup**, and then press .





4. Press ▲/▼ to scroll to **# of rings**, and then press .

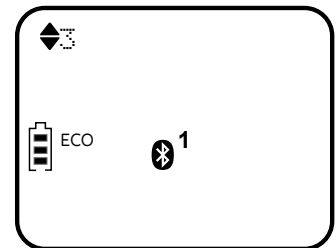

5. Press ▲/▼ to scroll to the desired number of rings, and then press .







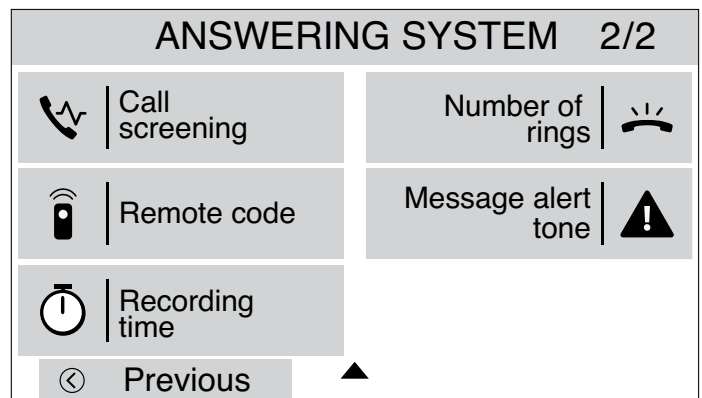

Base

1. Press **Menu** softkey.
2. Press  **Answering system**.
3. Press ▲/▼ to scroll to the next page, and then select **Number of rings** .





4. Press your desired number of rings.

NUMBER OF RINGS	
 2 Rings	5 Rings 
 3 Rings	6 Rings 
 4 Rings 	Toll Saver 

Message playback







You can listen to messages at the telephone base or on a cordless handset. When playback begins, the total number of messages is announced. Before each message, you hear the day and time of the recording. After the last message, you hear, "End of messages." Make sure you set the date and time correctly. Refer to **Set date and time** for more details.

Handset



1. Press  on the handset in idle mode.
2. Press  again to select **Play messages**. If you have either new or old messages, the messages play automatically.
3. The system announces the number of messages, then begins playback. The message sequence is shown on the handset's screen.

4. Press  to stop the playback.

Options during playback

- Press  to play the messages through the handset earpiece.
- Press  again to return to playing messages through the speakerphone.
- Press   to adjust the message playback volume.
- Press **6** to skip to the next message.
- Press **4** to repeat the message currently playing. Press **4** twice to listen to the previous message.
- Press **3** or  to delete the current message.
- Press  to stop the playback.

Base

1. Press  on the base to listen to the messages. If you have new messages, the telephone plays only the new messages (oldest first). If there are no new messages, the telephone plays back all messages (oldest first).
2. The system announces the number of messages, then begins playback. The message sequence is shown on the message window.
3. Press  to stop the playback.

Options during playback

- Press  to adjust the message

playback volume.

- Press **Skip** to skip to the next message.
- Press **Repeat** to repeat the message currently playing.
- Press **Repeat** twice to move to the previous message and play.
- Press to delete the current message. The system advances to the next message.
- Press to stop the playback.

Delete all messages

Handset

1. Press in idle mode.
2. Press to highlight **Answering sys**, then press .
3. Press to highlight **Delete all old**, then press
 - The handset displays **Deleting...**, then **No old messages** and then returns to the previous menu. You hear a confirmation tone.

Base

1. Press **Menu** in idle mode, and then select **Answering system**.
2. Press **Delete all old** .

Answering system remote access

You can reach your answering system

remotely by dialing your home telephone number from any touch-tone telephone.

1. Dial your telephone number from any touch-tone telephone.
2. Once the system plays your announcement, enter the two-digit remote access code (**19** is the default code).
 - The system automatically announces the number of new or old messages (if any), and then begins to play them.

You can also enter the following remote commands.

Commands	Description
1	Press to listen to all messages.
2	Press to listen to new messages only.
3	Press to delete the current message (during playback).
33	Press twice to delete all old messages.
4	Press to repeat the current message (during playback).
44	Press twice to listen to the previous message.
5	Press to stop.
*5	Press to listen to a list of remote commands.
6	Press to skip to the next message (during playback).
*7	Press to record a new announcement.
8	Press to hang up the call.
0	Press to turn the answering system on or off.

3. Hang up or press **8** to end the call.

NOTES

- If you do not enter a valid remote access code, the system answers the call automatically.
- Once the messages have played, the telephone announces the help menu options. If you do not press any key with 20 seconds, the remote access call ends automatically.
- If the memory is full, the answering system answers after 10 rings and announces, "Memory is full. Enter the remote access code." Enter your remote access code to access the messages and announcements.
- When the answering system is turned off, the telephone answers after 10 rings, and announces, "Please enter your remote access code."

Call intercept while using answering system

When a caller is leaving a message on your answering system, you can stop recording and talk to the caller by

pressing  or  on the handset.

Recording memo

Handset

1. Press  in idle mode.
2. Press  to highlight **Answering sys**, then press .
3. Press  to highlight **Record memo**,



then press .

- The handset displays **Recording...** and **Stop [5]**.
 - The system announces, "Record after the tone. Press 5 when you are done." Speak towards the handset microphone.
4. Press **5** to stop recording. The system announces, "Recorded." and then returns to the previous menu. The system does not save memos shorter than two seconds.

Base

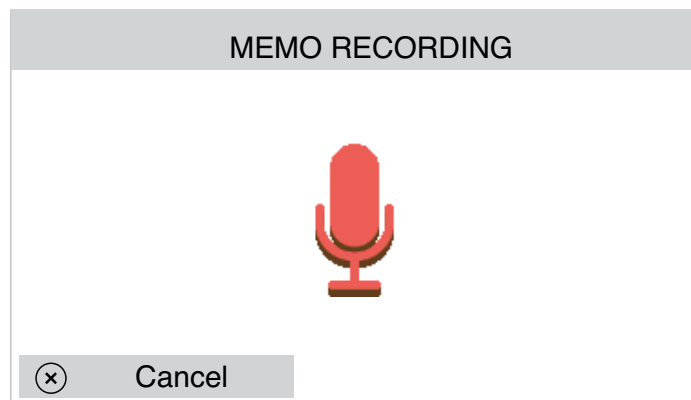
1. Press **Menu** in idle mode, and then select  **Answering system**.
2. Press **Record memo** .









- The system announces, "Record after the tone. Press 5 when you are done." Speak towards the base microphone after the tone.
3. When you are done, press  **Stop & Save** to end and save the recording.
 - Press  **Cancel** to cancel the recording.

Turn on/ off the call screening

Use this feature to choose whether incoming messages can be heard over the telephone base when they are being recorded. If you turn call screening on, you hear the incoming message.

Handset

1. Press  in idle mode.
2. Press  to highlight **Answering sys**, then press .
3. Press  to highlight **Ans sys setup**, then press  twice to select **Call screening**.
4. Press  to choose between **On** and **Off**, then press  to save.

Base

1. Press **Menu** in idle mode, and then select  **Answering system**.
2. Press  to  **Call Screening**.

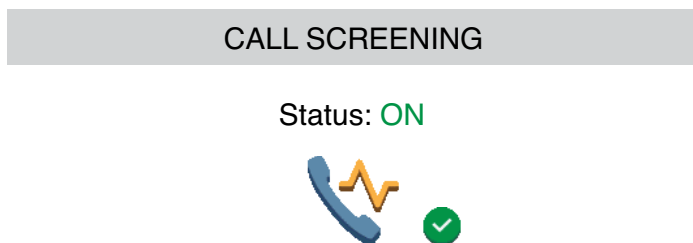

3. Press  **Back** or  **Turn OFF** to choose. Press  **Turn ON** or  **Turn OFF** to choose.





Screen a call with answering system

Screen calls at the cordless handset

If the answering system is on and a call is being answered by the answering system, the handset shows **To screen call press [SELECT]** at the same time.

Press  to screen the call on your handset. The handset shows the caller's information. If you do not subscribe to caller ID service, the handset shows **Screening....**



Options while a message is being recorded

- Press   on the handset to adjust the call screening volume.
- Press  to switch between speakerphone mode and handset mode.
- Press  to temporarily turn on the call screening if the call screening is set to off.
- Press  to temporarily turn off the call screening if the call screening is set to on.

Screen calls at the base

If the answering system and call screening are on, the announcement and the incoming message broadcast at the telephone base when a call is answered by the answering system.

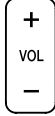
Options while a message is being recorded

- Press  on the telephone base to adjust the call screening volume.
- Press  on the base to answer the call.

Voicemail (via Telephone service provider)

When you received a voicemail, the handset and the telephone base display  and **New voicemail**.

To retrieve, you typically dial an access number provided by your telephone service provider, followed by a security code or PIN.

Some service providers bundle or combine multiple services like voicemail and call waiting, so you may not be aware that you have voicemail. To check what services you have and how to access them, contact your telephone service provider.

NOTE





- After you have listened to all new voicemail messages, the indicators on the screen turn off automatically.

Turn off the new voicemail indicators

If you have retrieved your voicemail while away from home, and the handset

and the telephone base still display the new voicemail indicators, use this feature to turn off the indicators.

This feature only turns off the displayed **New voicemail** and the ; it does not delete your voicemail messages. As long as you have new voicemail messages, your telephone service provider continues to send the signal to turn on the indicator.

1. Press  in idle mode.
2. Press  to highlight **Settings**, then press .
3. Press  to highlight **Clr voicemail**, then press  to turn the voicemail indicator off.

NOTES

- Your telephone service provider voicemail might alert you to new messages with a stutter (broken) dial tone. Contact your telephone service provider for more details.
- For information about using your voicemail service, contact your telephone service provider.

Activate and use cell phone's voice app via handset/telephone base

If you have paired a cell phone to the **IS8251 series** telephone system, you can activate the voice-controlled application (voice app) of the cell phone, such as Siri®, Google Now™ or S Voice®, using your handset.

The remote voice control feature works with

Voice-controlled application	Siri	Google Now	S Voice
Operation System (Versions supported)	iOS (8 or above)	Android (4 or above)	Android (4 or above)



Before using the remote voice control feature, make sure you checked the following:

- Your cell phone is paired and connected to your telephone system via Bluetooth.
- No Bluetooth applications are running in the background of your cell phone.
- Keep your cell phone within 15 feet of the telephone base.
- Do not lock up your cell phone's screen or set passcode for activating

the voice app.

- Make sure you have turned on or logged in to the applications on your cell phone that you will be sending your voice commands, such as GPS, e-mail and social networking accounts.
- Your cell phone's data or Wi-Fi signal is in full strength and your cell phone can connect to the Internet.
- Try to activate the voice app on your cell phone to ensure it is in place.

Activate remote voice control

1. Press  on the handset.
 - If you have connected one cell phone to the telephone, the handset shows the device name of the connected cell phone directly.
 - If you have connected two cell phones to the telephone, the handset shows **Select a device**, followed by the device name list of the connected cell phones. Scroll to choose the desired cell phone, and then press .
2. The handset then shows the remote voice control icon .
- If the activation fails, the handset displays **Not available**. When the screen returns to idle, try Step 1 again.
3. When the handset plays the confirmation tone as forwarded by the cell phone's voice app, start speaking toward the handset, and then wait

for feedback. Make reply to the voice app's feedback, if necessary.

- You can press  on the handset to turn off the speakerphone and listen to the feedback through the handset earpiece.



4. To end the current remote voice

control session, press  on the handset. You can restart by following Steps 1-3 mentioned above.

NOTES

- Once you have activated the remote voice control feature, you are using your cell phone's voice app to operate your cell phone.
- Please check the cell phone user's manual and the voice app's help topics to find out what commands you can use and any limitations of the voice app.
- Some cell phone manufacturers or network carriers may customize the phone's operating system and implement
- their own voice app. If you want to use Google Now, you need to manually set it as your default voice app. For detailed instructions, refer to your cell phone user's manual, or contact your cell phone's manufacturer or network carrier. You may also go to "Google Product Forums" on the Internet and check the corresponding help topics.
- Due to the settings of certain cell phones and voice apps, your cell phone may not support the remote

voice control feature. Contact your cell phone's manufacturer or network carrier, or check the voice app's help topics if you encounter any problems.

- During the remote voice control activation, if your Android cell phone comes with both a dedicated voice app and Google Now, it may prompt you to select which voice app to use, and whether use it for just once or always. Select the desired options. If you do not respond to your cell phone's prompt in time, the handset screen will return to idle, and the icon will disappear. You can restart by following Steps 1-3 mentioned above.
- If you receive a landline or cell line incoming call when you have activated remote voice control on a connected cell phone, the remote voice control operation will be ended.
- The feature may be ended automatically by your cell phone. For example, a cell call has been established via the
- remote voice control feature and the call has just ended.
- If you need to press dialing keys (**0-9**, , ) during a cell call, please make the call using the cell lines of your telephone system instead of using the voice app via the remote voice control feature.

Siri® is a registered trademark of Apple Inc.

Google Now™ is a trademark of Google Inc.

S Voice® is a registered mark of Samsung Electronics Co., Ltd.





IOS is a trademark or registered trademark of Cisco in the U.S. and other countries and is used under license.

Announcement



Your outgoing announcement plays when calls are answered by the answering system. The telephone has a default outgoing announcement, "Hello, please leave a message after the tone." You can use this announcement, or record your own.

Handset

Record a new outgoing announcement



1. Press  in idle mode.
2. Press  to scroll to **Answering sys**, then press .
3. Press  and select **Announcement**.
4. The screen displays **Play [2] Del [3] Rec [7]** and it announces, "To play, press 2. To record, press 7." Press **7** to record. The handset announces, "Record after the tone. Press **5** when you are done."
5. After the tone, speak towards the handset microphone. Press **5** to end recording. The newly recorded announcement automatically plays. To listen to the recorded announcement again, wait after playback has completed, then press **2**.

Play your announcement





1. Press  in idle mode.
2. Press  to scroll to **Answering sys**, and then press .

3. Press  and select **Announcement**.
4. The screen displays **Play [2] Del [3] Rec [7]** and it announces, "To play, press 2. To record, press 7." Press **2** to play the current announcement.

Options during playback

- Press   to adjust the listening volume.
- Press  to stop at any time.

Delete your announcement

1. Press  in idle mode.
2. Press  to scroll to **Answering sys**, then press .
3. Press  to select **Announcement**.
4. The screen displays **Play [2] Del [3] Rec [7]** and it announces, "To play, press 2. To record, press 7." Press **3** to delete your recorded announcement. The handset displays **Annc deleted** and announces, "Announcement deleted."

NOTE

- After you deleted your own recorded announcement, the answering system answers calls with the default announcement.

Screening announcements

If you have set profile to screen all unknown home calls (**Unknow caller**) or screen robocalls (**Robocalls only**),

the callers of the following incoming call categories will hear a screening announcement.

- Home calls that are "out of area" or with numbers set to "Private".
- Home calls with numbers that are not on your phonebook, allow list, or block list, or with absent caller ID number.
- Home calls with caller ID names that are not on your star name list.

There are two default screening announcements for screening unknown calls and screening robocalls on home line.

Screening with caller name - *"Hello. Calls to [this number/your recorded name] are being screened by Smart call blocker. Please say your name after the tone, then press pound."*

This default announcement is played if you have set profile to screen all unknown home calls.

-OR-



Screening without caller name - *"Hello. Calls to this number are being screened by Smart call blocker. If you're a family member, friend or invited caller, please press pound to be connected. If you're a solicitor, please hang up now."*

- This default announcement is played if you have set profile to screen robocalls on home line.





You can use these announcements,

or record your own name to replace "this number" in the announcements. (see **Record your name for screening announcements**)

Record your name for screening announcements

1. Press  to enter the main menu when the handset is not in use. Then, press ▲/▼ to scroll to **SCB settings**. Press .
2. Press ▲/▼ to scroll to **Screening annnc**, and then press .
3. Press ▲/▼ to select **Rec your name**. The system announces, "Record after the tone. Press 5 when you are done."
4. Speak towards the handset to record your name. Press **5** to end recording.





Play the screening announcement with your recorded name

1. Press  to enter the main menu when the handset is not in use. Then, press ▲/▼ to scroll to **SCB settings**. Press .
2. Press ▲/▼ to scroll to **Screening annnc**, and then press .
3. Press ▲/▼ to scroll to **SCB annnc type** and press .
4. Press  when you see **Unknown caller** (i.e. Unknown caller).
 - The announcement with

your recorded name plays automatically.

- Press **5** to stop the playback.

Reset all your screening announcements

1. Press  to enter the main menu when the handset is not in use. Then, press **▲/▼** to scroll to **SCB settings**. Press .
2. Press **▲/▼** to scroll to **Screening annnc**, then press .
3. Press **▲/▼** to scroll to **Reset SCB annnc**, then press .
 - The screen shows **Reset annnc?**
4. Press  to confirm.
 - The screen shows **Annc reset**.
 - Before returning to the previous menu, your name will be deleted from all the screening announcements, and the telephone will use the default screening announcements.

Base

Record a new outgoing announcement

1. Press **Menu** in idle mode.
2. Press  **Answering system**.

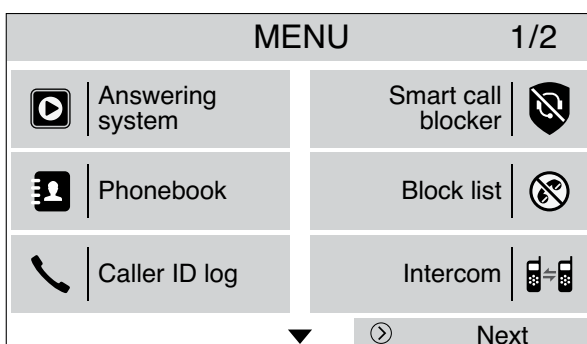

3. Press  **Outgoing announcement**.

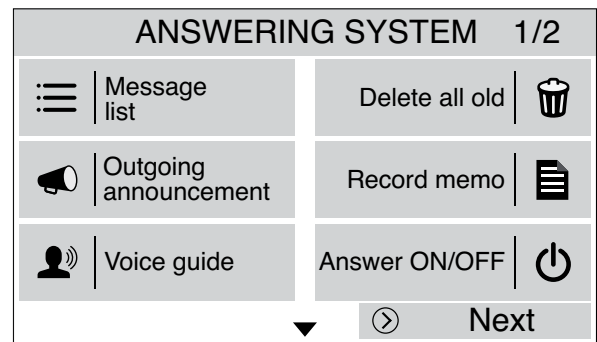

4. Press  **Record** to record your announcement.
 - The system announces, "Record after the tone. Press **5** when you are done."



5. After the tone, speak towards the base microphone.
 - Press **5** on the base to end the recording.
 - Press **Stop & Save** to confirm.
 - Press **Cancel** to cancel the recording.

To listen to the recorded announcement, press **Play**.

Play your announcement

1. Press **Menu** in idle mode.
2. Press  **Answering system**.
3. Press **Play**.

Options during playback

- Press  to adjust the listening volume.
- Press **Stop** to stop at any time.



Delete your announcement

1. Press **Menu** in idle mode.
2. Press  **Answering system**.
3. Press ↻ **Default**.
 - The screen shows **Reset to default announcement?**
4. Press **Yes** to delete your recorded announcement. The screen displays **Announcement reset to default**.

NOTE

- After you deleted your own recorded announcement, the answering system answers calls with the default announcement.

Screening announcements

If you have set profile to screen all unknown home calls **Unknown caller**  or screen robocalls **Robocalls only** , the callers of the following incoming call categories will hear a screening announcement.

- Home calls that are “out of area” or with numbers set to “Private”.
- Home calls with numbers that are not on your phonebook, allow list, or block list, or with absent caller ID number.

- Home calls with caller ID names that are not on your star name list.

The are two default screening announcements for screening unknown calls and screening robocalls on home line.

Screening with caller name - *“Hello. Calls to [this number/your recorded name] are being screened by Smart call blocker. Please say your name after the tone, then press pound.”*

- This default announcement is played if you have set profile to screen all unknown home calls.



-OR-

Screening without caller name - *“Hello. Calls to this number are being screened by Smart call blocker. If you’re a family member, friend or invited caller, please press pound to be connected. If you’re a solicitor, please hang up now.”*

- This default announcement is played if you have set profile to screen robocalls on home line.

You can use these announcements, or record your own name to replace “this number” in the announcements. (see **Record your screening announcements for Unknown callers or Robocalls**)

Record your screening announcements for Unknown callers or Robocalls

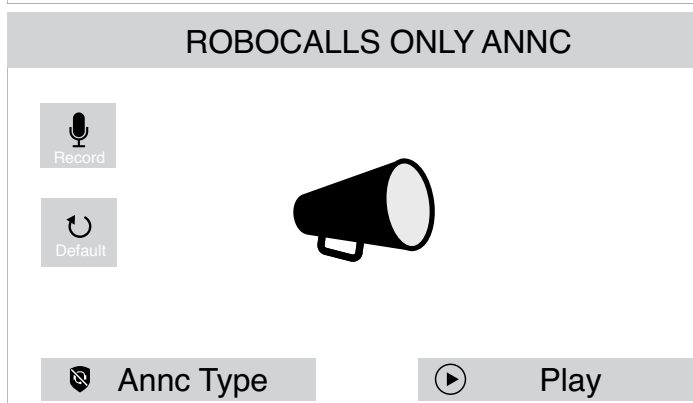
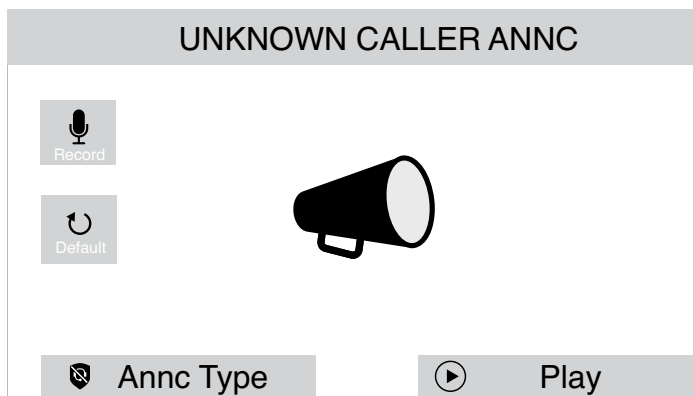

1. Press **Menu** in idle mode.
2. Press **Smart call blocker** .
3. Press  **Screening ann.**

4. Press  **Annc Type** to choose between  **Unknown caller** and  **Robocalls only**.







5. Press  **Record** to record your announcement.
 - The system announces, "Record after the tone. Press 5 when you are done."

Play the screening announcements for Unknown callers or Robocalls with your recorded name

1. Press **Menu** in idle mode.
2. Press **Smart call blocker** .
3. Press  **Screening annc.**
4. Press **Play** on either **Unknown Caller Annc** or **Robocalls only Annc**.
 - The announcement with your recorded name plays automatically.

- Press **Stop** to stop the playback.

Reset all your screening announcements

1. Press **Menu** in idle mode.
2. Press **Smart call blocker** .
3. Press  **Screening annc.**
4. Press  **Annc Type** to choose between  **Unknown caller** and  **Robocalls only**.

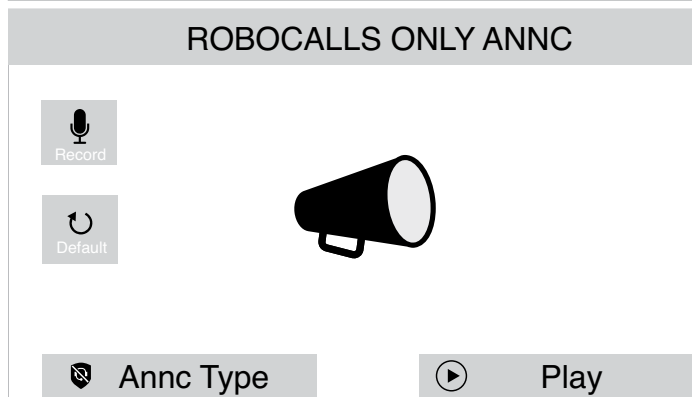
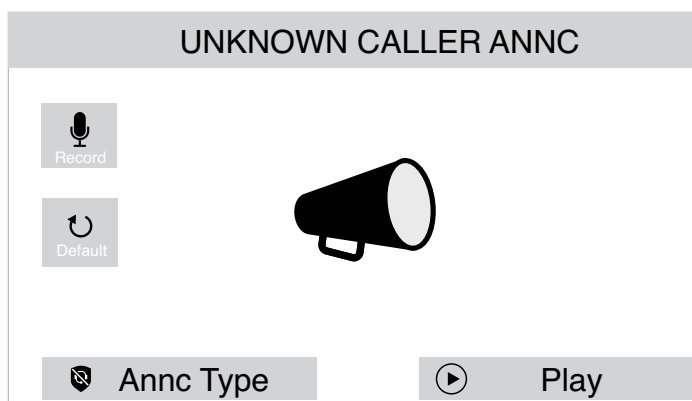

5. Press their respective  **Default** to reset your announcement.

Before returning to the previous menu, your name will be deleted from all the screening announcements, and the telephone will use the default screening announcements.

Smart call blocker (SCB)



If you have subscribed to caller ID service, then you can use the Smart call blocker feature to screen incoming calls.

NOTES



- The screening feature of Smart call blocker is applicable to incoming home calls only.
- All incoming cell calls will get through and ring. If you want to block a cell call, add the number to block list.

The Smart call blocker feature is set to on by default.

Handset - Method 1

1. Press , and **SCB screening** displays. Press  to select.
2. Press ▲/▼ to scroll to your preferred options of Smart call blocker, including **No screening** option.
3. Press  to select to save the settings. You hear a confirmation tone.

Handset - Method 2





1. Press  and ▲/▼ to scroll to **SCB screening**. Press  to select.
2. Press ▲/▼ to scroll to your preferred options of Smart call blocker, including **No screening** option.
3. Press  to select to save the

settings. You hear a confirmation tone.

TIP

- To allow all calls to ring through, you just need to select **No screening** option and no contact or number in **Block list**.

Base

1. Press **Menu** softkey and choose **Smart call blocker** , and then **SCB screening** .
2. Press and select **Screen unknown** 
 - **Screen all unknown calls** displays and confirms.
 -  next to the selected option.

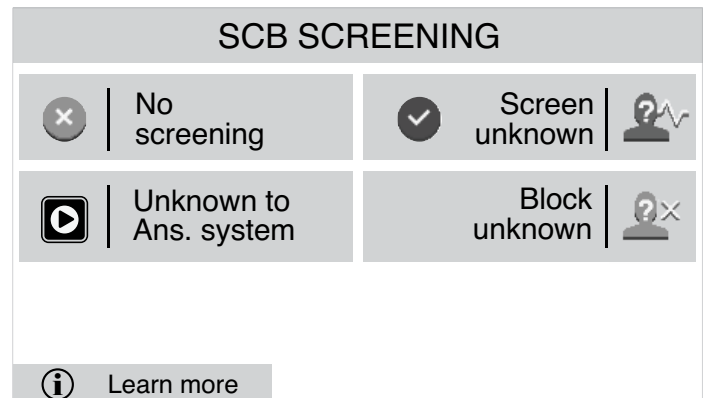

Select the **Screen unknown**  profile option will set your telephone to screen all unknown home calls and ask for the callers' names before putting the calls through to you.













TIP

















- To allow all calls to ring through, you just need to select **No screening** option and no contact or number in **Block list**.

Set SCB screening profile

There are five profile options, which allows you to quickly set up Smart call blocker with your handset and base.

Handset













Set profile	Steps
Screen unknown Screen all unknown home calls	<ol style="list-style-type: none"> 1. Press CALL BLOCK. 2. Press ▲ or ▼ → SCB screening → . 3. Press ▲ or ▼ → Screen unknown → .
Screen robot Screen robocalls	<ol style="list-style-type: none"> 1. Press CALL BLOCK. 2. Press ▲ or ▼ → SCB settings → . 3. Press ▲ or ▼ → Screening annc → . 4. Press ▲ or ▼ → SCB annc type → . 5. Press ▲ or ▼ → Robocalls only → .
Allow unknown No screening Block calls on the block list only (default settings)	<ol style="list-style-type: none"> 1. Press CALL BLOCK. 2. Press ▲ or ▼ → SCB screening → . 3. Press ▲ or ▼ → No screening → .
UnknownToAns.S Forward all unknown home calls to the answering system	<ol style="list-style-type: none"> 1. Press CALL BLOCK. 2. Press ▲ or ▼ → SCB screening → . 3. Press ▲ or ▼ → UnknownToAns.S → .
Block unknown Block all unknown home calls	<ol style="list-style-type: none"> 1. Press CALL BLOCK. 2. Press ▲ or ▼ → SCB screening → . 3. Press ▲ or ▼ → Block unknown → .

Set profile	Steps
Screen unknown Screen all unknown home calls	<ol style="list-style-type: none"> 1. Press Menu softkey, and choose Smart call blocker . 2. Press  SCB screening. 3. Press and select Screen unknown .
Screen robot Screen robocalls	<ol style="list-style-type: none"> 1. Press Menu softkey, and choose Smart call blocker . 2. Press  Screening annc, then press and select  Annc Type. 3. Press and select Robocalls only .
Allow unknown No screening Block calls on the block list only (default settings)	<ol style="list-style-type: none"> 1. Press Menu softkey, and choose Smart call blocker . 2. Press  SCB screening. 3. Press and select  No screening.
UnknownToAns.S Forward all unknown home calls to the answering system	<ol style="list-style-type: none"> 1. Press Menu softkey, and choose Smart call blocker . 2. Press  SCB screening. 3. Press and select  Unknown to Ans. system.
Block unknown Block all unknown home calls	<ol style="list-style-type: none"> 1. Press Menu softkey, and choose Smart call blocker . 2. Press  SCB screening. 3. Press and select Block unknown .







Set up Block list

Handset

Add a new entry directly to the block list

1. Press .
2. Press  → **Block list** → .
3. Press  → **Add new entry** → .
4. Enter a telephone number up to 30 digits → .
5. Enter a name up to 15 characters → 
 - Use the dialing keys to enter a name. Press a key repeatedly until the desired character appears. The first character of every word is capitalized.
 - Press  to move the cursor to the left or right.
 - Press **0** to add a space.
 - Press  on the handset to erase a digit and a character.
 - Press and hold  on the handset to erase all digits and all characters.
 - Press and hold  to enter a three-second dialing pause (a **P** appears).
 - Press  to change the next letter to upper or lower case.
6. Press  to store your block entry.







Add an entry from caller ID log to the block list

1. Press  →  (to scroll to the desired entry) → .
2. Press  → **To Block list** → .
3. Press  twice to confirm the autofilled CID number and CID name.
 - The display show **Saved**.

NOTES

- When the number is already in the block list, the display shows **Number repeated**. You cannot save the same number twice.
- When the Block list is full upon saving a new entry, the display shows **Block list is full**.

Review block list







1. Press .
2. Press  → **Block list** → .
3. Press  → **Review** → 
 - The display shows total number of entries.
4. Press  to browse through the block entries.

NOTE



- **List empty** appears if there are no block entries.

Edit a block list entry

1. Search for the desired entry in the block list (see **Review block list**).



- Press  to select the entry.
- Edit the existing number → .
- Edit the existing name → .
 - Telephone number up to 30 digits.
 - Name up to 15 characters.
 - Use the dialing keys to enter a name. Press a key repeatedly until the desired character appears. The first character of every word is capitalized.
 - Press ▲/▼ to move the cursor to the left or right.
 - Press 0 to add a space.
 - Press  on the handset to erase a digit and a character.
 - Press and hold  on the handset to erase all digits and all characters.
 - Press and hold  to enter a three-second dialing pause (a P appears).
 - Press  to change the next letter to upper or lower case.

Delete all block list entries

- Press .
- Press ▲/▼ → **Block list** → .
- Press ▲/▼ → **Delete all** → .

Unblock a telephone number

- Search for the desired entry in the block list (see **Review block list**).

- Press  to select the entry.
- Press  to delete →  to confirm.

Base

Add a new entry directly to the block list

- Press **Menu** → **Block list** .

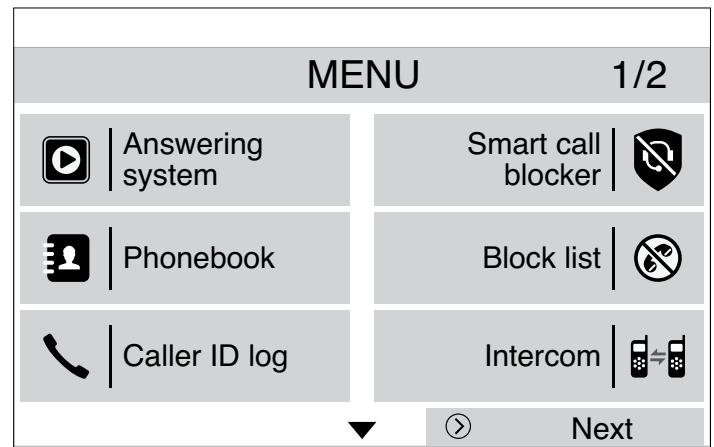

- Press **Block numbers**.
 - If you need to add prefix to the block number, press **Prefix of block numbers**.

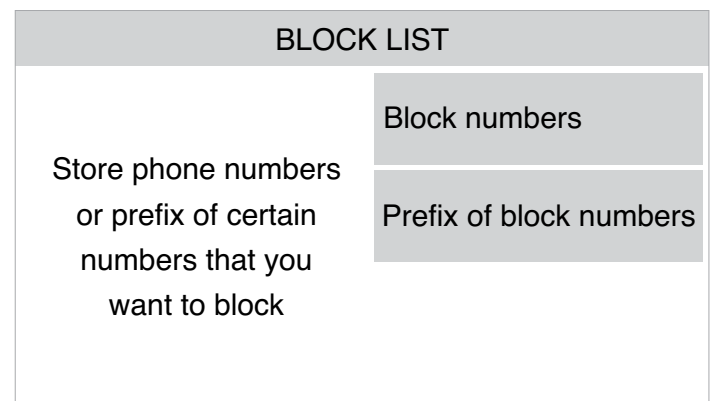

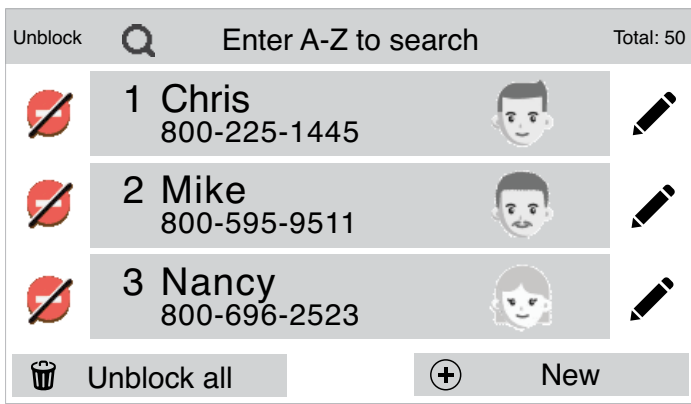

3. Press **NEW** → enter a telephone number → **Next**.
 - Press **Backspace** to edit.
4. Enter the Block name (Optional).
 - Press **Skip** if needed.

Add an entry from caller ID log to the block list

1. Press **CID** → \triangle/∇ (to scroll to the desired entry) → **Edit**.
2. Press **...** → **Block list** .
 - Press **Edit** if you need to change the existing number and name. Press **Save** to confirm the change and to save.
3. Press **Yes** to save.

Review block list

1. Press **Menu** → **Block list** .
2. Press **Block numbers**.
3. Press \triangle/∇ to browse through the block entries.

Edit a block list entry

1. Search for the desired entry in the block list (see **Review block list**).

2. Press next to that entry.
3. Edit the existing number → **Next**.
 - Use the dialing keys to enter digits.
 - Press \triangle/∇ to move the cursor to the left or right.
 - Press **BACKSPACE** to erase a digit.
 - Press **BACKSPACE** repeatedly to erase all digits.
 - Press and hold to enter a three-second dialing pause (a **P** appears).
4. Edit the existing name → **Save**.
 - Use the dialing keys to enter characters.
 - Press \triangle/∇ to move the cursor to the left or right.
 - Press **0** to add a space.
 - Press **BACKSPACE** to erase a character.
 - Press **BACKSPACE** repeatedly to erase all characters.
 - Press to change the next letter to upper or lower case.

Remove/ Unblock all block list entries

1. Press **Menu** → **Block list** .
2. Press **Block numbers**.
3. Press **Unblock all**.

Unblock a telephone number

1. Press **Menu** softkey, and then go to Block list .
2. Press **Block numbers** smart key, and press \triangle/∇ to review and browse

through the block list.

3. When the desired entry displays, press the  smart key to unblock.
 - The screen shows **Unblock entry?** with the entry name and telephone number.
4. Press **Yes** to unblock.











Smart call blocker settings

Star name entry/ list

There are many organizations like schools, medical offices, and pharmacies that use robocalls to communicate important information to you. Robocall uses an autodialer to deliver pre-recorded messages. By entering the name of the organizations into the star name list, it ensures these calls will ring through when you only know the caller names but not their numbers. **If the first 15 characters of the incoming caller ID's name match a name saved in your star name list, the call will get through and ring.** The star name list stores up to 10 names.

Handset

Add a star name entry

1. Press  to enter the main menu when the handset is not in use. Then, press / to scroll to **SCB settings**. Press .
2. Press / to scroll to **Star name list**, and then press .
3. Press / to scroll to **Add new entry**, then press .
4. When the screen displays **Enter name**, use the dialing keys to enter a name (up to 15 characters). Press a key repeatedly until the desired character appears. The first character of every

word is capitalized.

- Press ▲/▼ to move the cursor to the left or right.
- Press 0 to add a space.



- Press  on the handset to erase a character.







- Press and hold  on the handset to erase all characters.





- Press  to change the next letter to upper or lower case.

5. Press  to store your star name entry.
 - The display shows **Name repeated** if the name is already in the star name list. You cannot save the same name twice.





Review star name list

1. Press  to enter the main menu when the handset is not in use. Then, press ▲/▼ to scroll to **SCB settings**. Press .
2. Press ▲/▼ to scroll to **Star name list**, and then press .
3. Press ▲/▼ to scroll to **Review**, then press .
4. Press ▲/▼ to browse through the star name entries.







Delete all star name entries

1. Press  to enter the main menu when the handset is not in use. Then, press ▲/▼ to scroll to **SCB settings**. Press .
2. Press ▲/▼ to scroll to **Star name list**, and then press .
3. Press ▲/▼ to scroll to **Delete all**, then press .
 - The handset shows **Delete all?**.
4. Press  again to confirm. The handset displays **Deleting...** There is a confirmation tone.

Edit a star name entry

1. Search for the desired entry in the allow list (see **Review star name list**).
2. Press . The screen displays Enter name along with the name to be edited.
3. To edit the name
 - Press ▲/▼ to move the cursor to the left or right.
 - Press 0 to add a space.
 - Press  on the handset to erase a character.
 - Press and hold  on the handset to erase all characters.
 - Press  to change the next letter to upper or lower case.
4. Press  to save the entry. You hear a confirmation tone.

Save a caller ID log entry to star name list Review star name list

1. Press  →  (to scroll to the desired entry) →  .
2. Press  → **To Star name** →  .
3. The handset displays **Star the name?**.
4. Press  to confirm. You hear a confirmation tone.

NOTES

- When the number is already in the star name list, the display shows **Number repeated**. You cannot save the same number twice.
- When the Star name list is full upon saving a new entry, the display shows **Memory full**.

Base

Add a star name entry

1. Press **Menu** → **Smart call blocker**  → **Star name list**  .

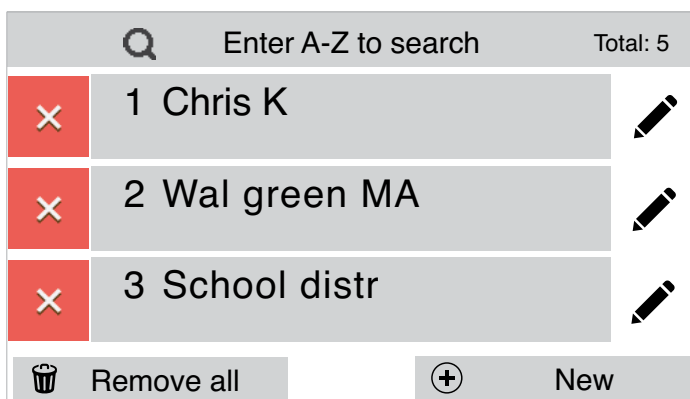

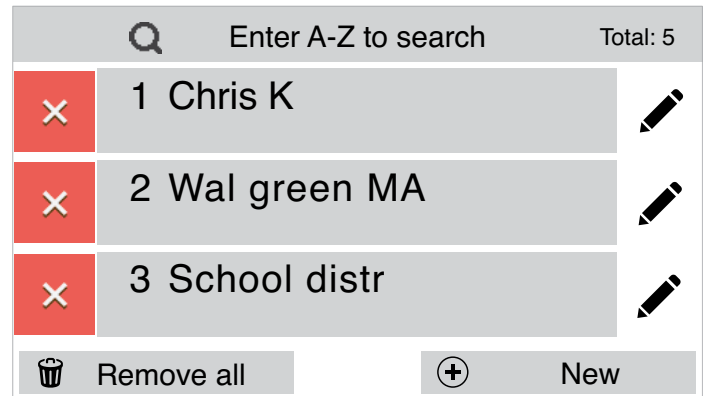

2. Press **NEW** → enter a Star Name → **Save**. You hear a confirmation tone.

1. Press **Menu** → **Smart call blocker**  → **Star name list**  .



2. Press  to browse through the entries.

Delete/ Remove all star name entries

1. Press **Menu** → **Smart call blocker**  → **Star name list**  .
2. Press  **Remove all**.

Delete/ Remove a star name entry

1. Search for the desired entry in the star name list (see **Review star name list**).
2. Press  next to the desired entry to delete. The screen shows **Remove from Star name list?**.
3. Press **Yes**. You hear a confirmation tone.

Answering system settings

Set your built-in answering system

The answering system can record and store up to 99 messages. Each message can be up to 3 minutes in length. The total storage capacity for the announcement, messages and memos is approximately 41 minutes. The actual recording time depends on individual message characteristics. Messages remain available for replay until you delete them.

Set answering system through voice guide

This feature is an alternative way for you to do the basic setup of the answering system. You can follow the voice guide to set up the answering system.

Press **Menu** →  **Answering system** → **Voice guide**. You hear a voice prompt, "This voice guide will assist you with the basic setup of your answering system."

NOTES

- You can press  to quit the voice guide at any time.
- After a power outage, the telephone base prompts you to set the date and time, and Smart call blocker. After these settings are done or skipped, the telephone base then prompts







if you want to set up the answering system via voice guide. Follow the instructions to start the setup.

Change remote access code

To access your answering system remotely from any touch-tone phone, you need to enter a two-digit number (00-99). By default, the remote access code is **19**. See [Answering system remote access](#).

Handset

To change the remote access code:



- Press  in idle mode.
- Press  to highlight **Answering sys**, then press .
- Press  to highlight **Ans sys setup**, then press .
- Press  to highlight **Remote code**, then press .
- Use the dialing keys to enter a two-digit number.

-OR-

Press  to scroll to a desired two-digit number.

- Press  to confirm.









Base

- Press **Menu** →  **Answering system** →  →  **Remote code**.
- Use the dialing keys to enter a two-digit number.
- Press **Save** to confirm.



Turn on or off the message alert tone

When the message alert tone is set to **On**, and there is at least one new message, the telephone base beeps every 10 seconds. The tone stops when all new messages have been reviewed. By default, the message alert tone is **Off**.

Handset

1. Press  in idle mode.
2. Press  to highlight **Answering sys**, then press .
3. Press  to highlight **Ans sys setup**, then press .
4. Press  to highlight **Msg alert tone**, then press .
5. Press  to choose **On** or **Off**, then press .

Base

1. Press **Menu** →  **Answering system** →  → **Message alert one** .
2. Press **Turn ON** to turn on.
 - **Message alert tone ON** displays.

NOTES

- Press any base keys except  to temporarily disables the message alert tone until a new message is received.
- The message alert tone beeps only if all the following conditions are met.
 - Answering system is on.

- Message alert tone setting is on.
- There are new messages.

Dial modes

Temporary tone dialing

If you have pulse (rotary) service only, you can switch from pulse to touch-tone dialing temporarily during a call. This is useful if you need to send touch-tone signals to access your telephone banking or long distance services.





During a call

1. Press  on the handset.
2. Use the dialing keys to enter the relevant number. The telephone sends touch-tone signals.
3. The telephone automatically returns to pulse dialing after you end the call.

Set dial mode

The dial mode is preset to tone dialing. If you have pulse (rotary) service, you must change the dial mode to pulse dialing before using the telephone.

To set the dial mode

1. Press  in idle mode.
2. Press ▲/▼ to highlight **Settings**, then press .
3. Press ▲/▼ to highlight **Dial mode**, then press .
4. Press ▲/▼ to choose **Touch-tone** or **Pulse**, then press .

NOTE

- If you have dial pulse (rotary) dialing service only, refer to **Temporary tone dialing** to temporarily switch from pulse to touch-tone dialing during a call.

Ringers







You can select the ringtone and volume for incoming home and cell calls.

Set home/cell ring volume







You can select the ringer volume for incoming home and cell calls. A ringer off icon  shows on the handset when the volume is set to off.

Handset

To set the ringer volume on home line

1. Press  in idle mode.
2. Press  to highlight **Ringers**, then press .
3. Press  to select **Home volume**.
4. Press  to sample each ringer volume for home line.
5. Press  to save.

To set the ringer volume on cell lines

1. Press  in idle mode.
2. Press  to highlight **Ringers**, then press .
3. Press  to select **Cell volume**, then press .
4. Press  to sample each ringer volume for cell lines.
5. Press  to save.

Base

To set the ringer volume on home line/cell lines

1. Press **Menu** →  → **Ringers** .

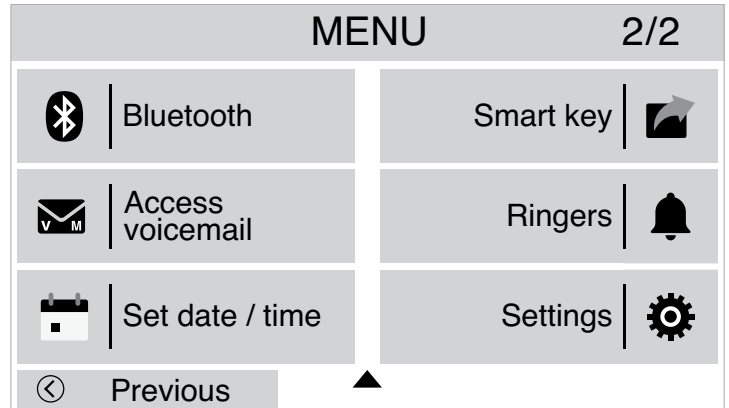

2. Press  **Home** or **Cell 1/ Cell 2** .

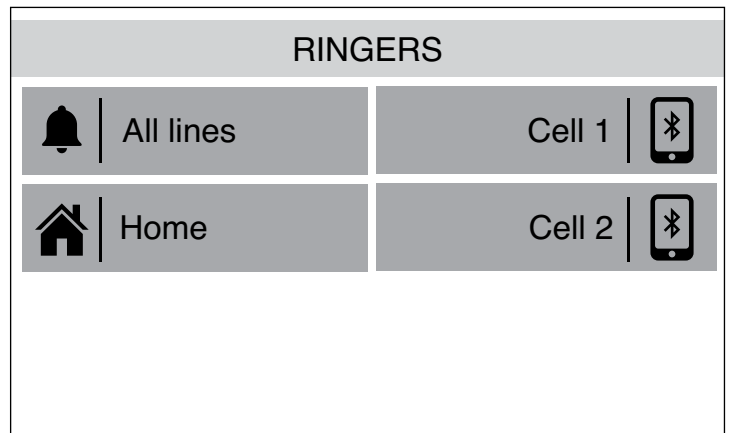

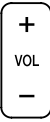
3. Press  or the smart keys next to the sound bar (- / +).

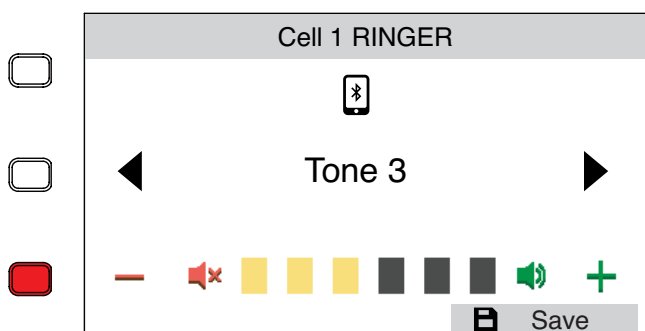
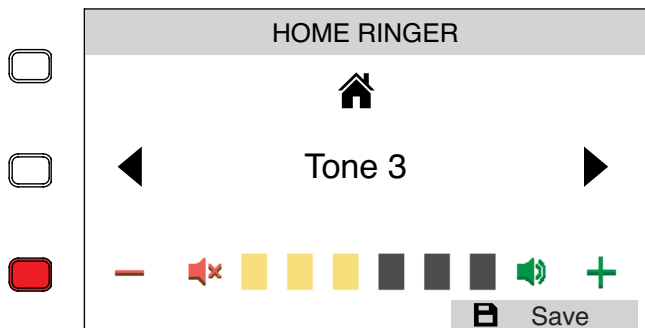

4. Press **Save** to confirm.





NOTES

- Changing the handset ringer volume does not affect base ringer volume.
- If the ringer volume is set to off, that handset or the telephone base is silenced for all incoming calls.
- The ringer volume level also determines the ringer levels of intercom calls.





Set home/ cell ringtone

Handset

To set the ringtone on home line

1. Press  in idle mode.
2. Press ▲/▼ to highlight **Ringers**, then press .
3. Press ▲/▼ to select **Home ringtone**, then press .
4. Press ▲/▼ to sample each ring tone for home line.
5. Press  to save.

To set the ringtone on cell lines

1. Press  in idle mode.
2. Press ▲/▼ to highlight **Ringers**, then press .
3. Press ▲/▼ to select **Cell ringtone**, then press .
4. Press ▲/▼ to sample each ringtone for cell lines.
5. Press  to save.

Base

To set the ringtone on home line/ cell lines

1. Press **Menu** → \triangle/∇ → **Ringers** .

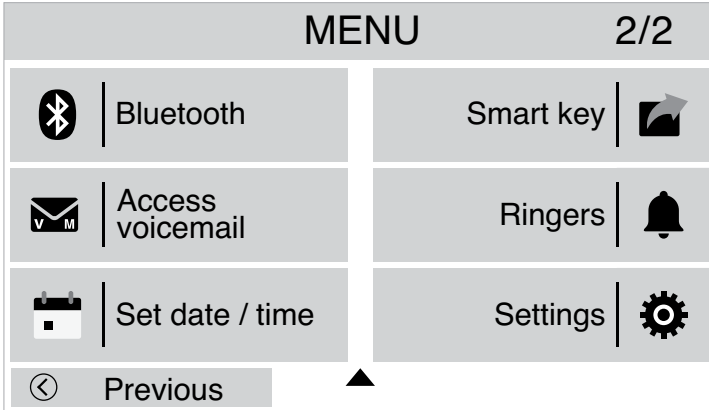

2. Press  **Home** or **Cell 1/ Cell 2** .

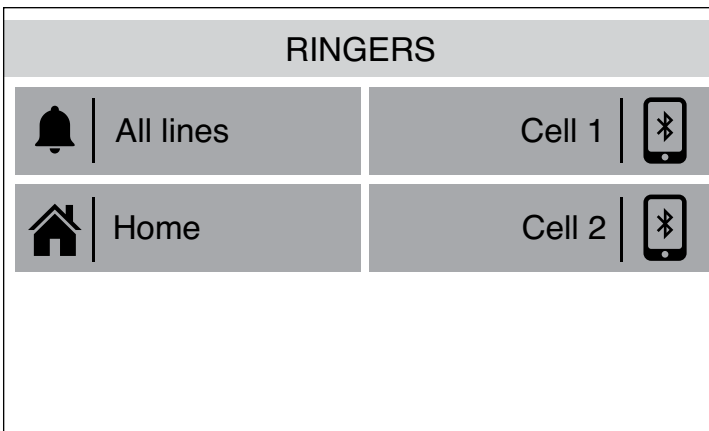

3. Press \triangle/∇ or the smart keys next to the Tone option (\triangle/∇) to sample each ringtone.

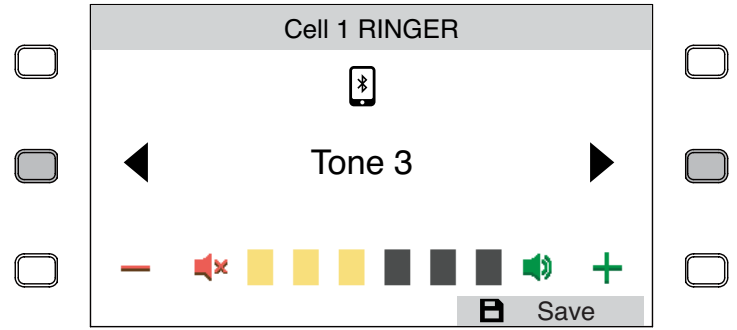
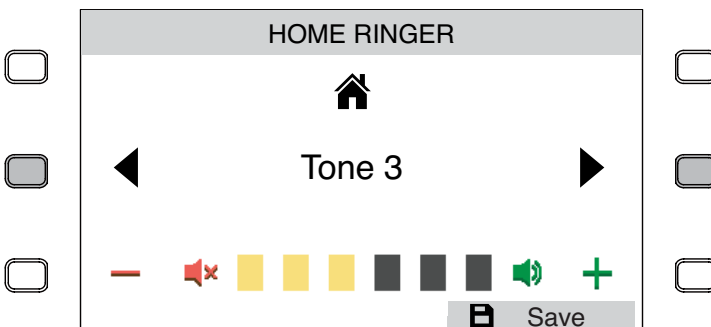

4. Press **Save** to confirm.

NOTE

- When you turn off the ringer volume, you will not hear ringer tone samples.



Date and time



Set date and time

The answering system announces the day and time of each message prior to playing it. Before using the answering system, set the date and time as follows. If you subscribe to caller ID service, the day, month and time are set automatically with each incoming call. However, the year must be correct so that the day of the week can be calculated from the caller ID information.

After handset registration or a power failure, the handset will prompt you to set the date and time.

Handset

1. Press  in idle mode.
2. Press \triangle/∇ to highlight **Set date/ time**, then press .

3. Enter the month/ date/ year (**MM/DD/YY**) using the dialing keys.
4. Press  to move on to set the time.
5. Enter the hour / minute (**HH:MM**) using the dialing keys.
6. Press  to confirm.

Base

1. Press **Menu** →  →  **Set date / time**.

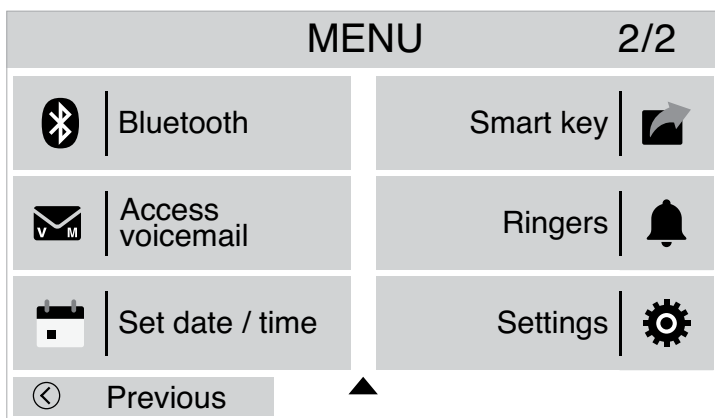

2. Use the dialing keys (**0-9**) to enter the month (--), date (--) and year (--). Then, press **Next**.

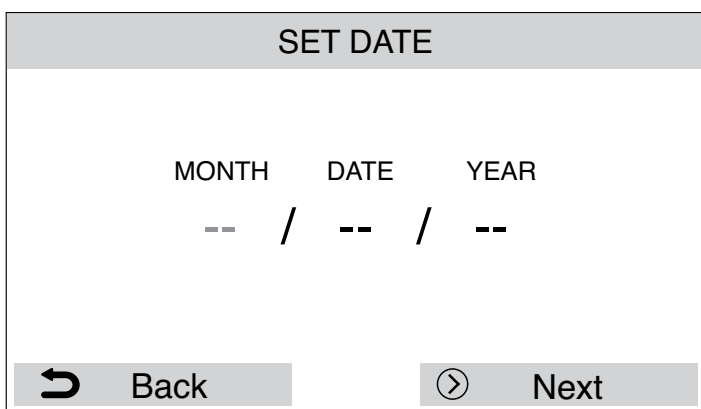

3. Use the dialing keys (**0-9**) to enter the hour (**HH**) and minute (**MM**). Then, press  to choose **AM** or **PM**.
4. Press **Save** to save.

TIP







- To skip setting the date and time, press  on the base.

LCD languages

Select LCD language

You can select English, French, or Spanish to be used for all screen displays.

Handset

1. Press  in idle mode.
2. Press  to highlight **Settings**, and then press .
3. Press  to select **LCD language**.
4. Press  to highlight **English**, **Français** or **Español**, and then press  to confirm.

Base

1. Press **Menu** →  → **Settings** .

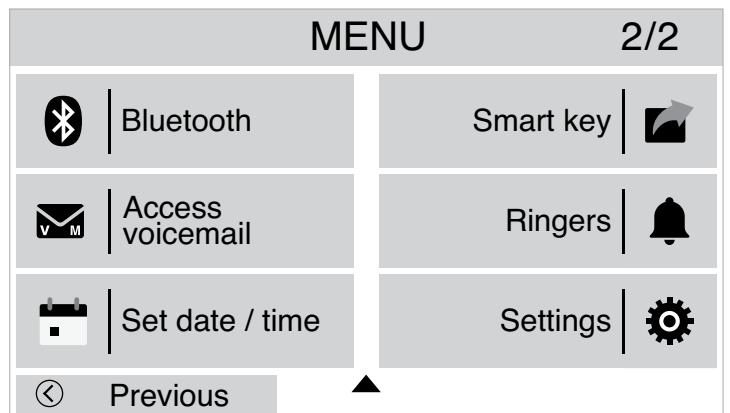

2. Press  **LCD language**.

3. Select between  English,  Français or  Español, and then press **Yes** to confirm.

NOTE

- If you accidentally change the LCD language to French or Spanish, you can reset it back to English without going through the French or Spanish menus. Press  in idle mode, then enter ***364**#. There is a confirmation tone.



Sound settings

Set **QUIET** mode

When **QUIET** mode is turned on, the telephone silences all sounds during the set period of time (1-12 hours). However, the handset locator paging tone and any sound-generating operations initiated by users, such as making calls using the speakerphone or setting ringer volume, will sound as normal. After you turn on **QUIET** mode, this feature activates immediately and the answering system turns on automatically.

When **QUIET** mode is on, the answering system takes calls and records messages without broadcasting them.

To turn **QUIET** mode on

1. Press and hold  in idle mode to enter the **QUIET** mode setting screen. The screen shows **Quiet: _ _ hours [1-12]**.
2. Use the dialing keys to enter the desired number of hours (1-12) you would like to turn on **QUIET** mode, then press . Your screen shows **Quiet mode on**.

To turn **QUIET** mode off

While **QUIET** mode is on, press and hold . The screen shows **Quiet mode off** briefly and then returns to idle.

NOTES

- If you change the base ringer, handset

ringer, ringer volume, or key tone when **QUIET** mode is on, the sample plays but the feature is still muted after saving the setting.

- After **QUIET** mode is turned off or the set period of time has expired, all muted features will be activated again.
- When **QUIET** mode is on, and Smart call blocker is on and in screening mode, all screened home calls will be sent to the answering system after screening.

Adjust listening volume

While on a call or message playback, you can adjust the listening volume on the handset or telephone base.

If it is a cell call and the volume is too loud, too quiet or drops out, try changing the volume on your cell phone. On some cell phones, changing the volume on the cell phone affects your cell call volume on the handsets.

Handset

- Press  on the handset while on a call.

Base

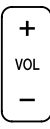





- Press  while listening to the message playback on the telephone base.

Set key tone

The handset is set to beep with each key press. You can adjust the key tone volume or turn it off.

If you turn off the key tone, there are no beeps when you press keys.





Handset

1. Press  in idle mode.
2. Press  to highlight **Settings**, then press .
3. Press  to highlight **Key tone**, then press .
4. Press  to select **On** or **Off**.
5. Press  to confirm.

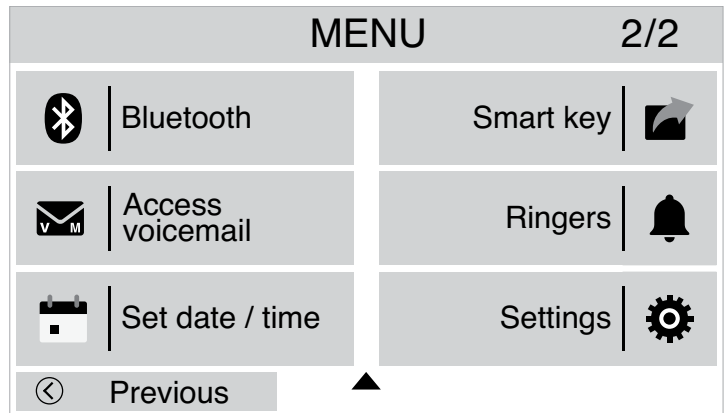
Base

1. Press **Menu** →  → **Settings** .



2. Press  **Key tone** →  or the smart keys ( / ).

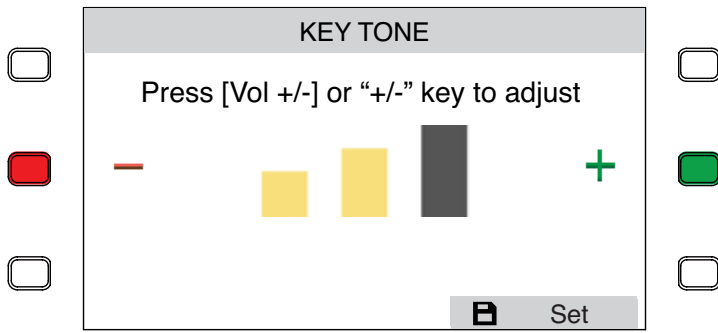

3. Press **Set** to confirm.

Other settings

Clear voicemail

To clear/ remove the voicemail indication, press **Menu** → △/▽ → **Settings** ⚙️. Then, press **Clear voicemail** 🗑️📧.

- Press **Yes** to confirm.
- Press **No** to return to previous page.

Dim mode

You can set the base's LCD screen to be dimmed after selected period of time.

1. Press **Menu** → △/▽ → **Settings** ⚙️.
2. Press **Dim mode** 🌙.
3. Select **Do not dim**, **1 minute**, or **3 minutes**.

Brightness

You can set the base's LCD screen brightness.

1. Press **Menu** → △/▽ → **Settings** ⚙️. → △/▽ → **Brightness** ☀️.



2. Press the smart key (− / +) or ◀/▶ to adjust.
3. Press **Set** to confirm.

Wallpaper

You can change the mood of the base's LCD screen by changing its background with a range of wallpaper.

1. Press **Menu** → △/▽ → **Settings** ⚙️.
2. Press **Wallpaper** 🖼️.

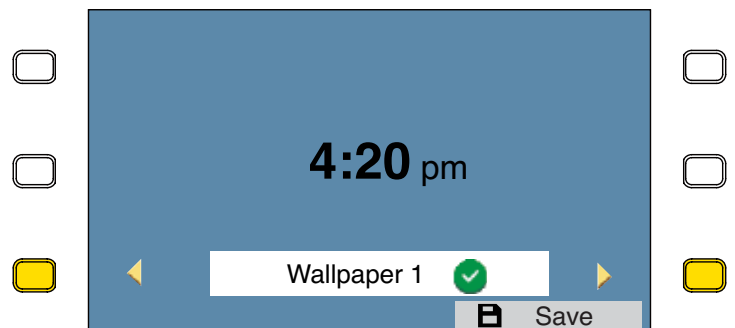

3. Press the smart key (◀ / ▶) or ◀/▶ to adjust.
4. Press **Save** to confirm.

Countdown timer

You can use the timer as your kitchen timer for cooking, meeting timer, exercise timer, study timer, and etc. It assists you to be multitasking while working from home, so that you can better manage your time. This feature is only available on the telephone base. You can set the duration to count down from. When the time is up, the alert sounds and a text message pops up.

Set the countdown timer

1. Press **TIMER**.
2. Enter your desired number of minutes and seconds with the numeric keys. You can also press \triangle/∇ to edit the number of minute and seconds, and then press $\triangleleft/\triangleright$ to move between **MINUTES** and **SECONDS**.

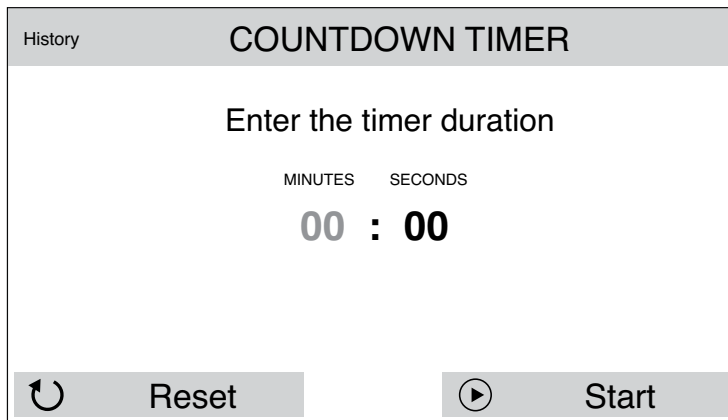

- You will see the **MINUTES** start flashing.

3. Press **Start** to start counting down.

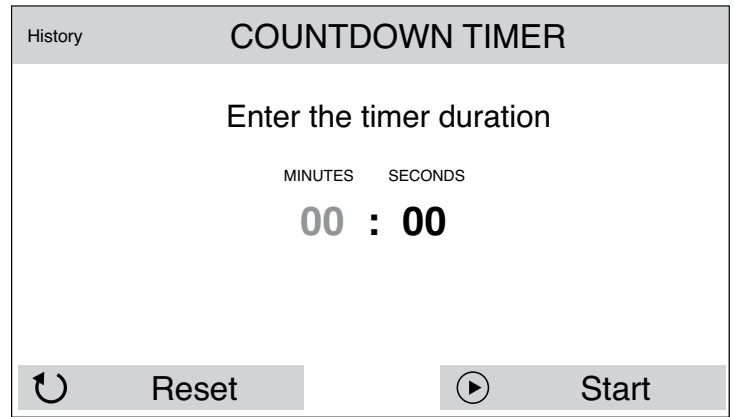

4. Press **Pause** to temporary stop the countdown. You can resume the counting by pressing **Resume**. If you want to stop the countdown, press **Stop**.



General product care

Taking care of your telephone

Your cordless telephone contains sophisticated electronic parts, so it must be treated with care.

Avoid rough treatment

Place the handset down gently. Save the original packing materials to protect your telephone if you ever need to ship it.

Avoid water

Your telephone can be damaged if it gets wet. Do not use the handset outdoors in the rain, or handle it with wet hands. Do not install the telephone base near a sink, bathtub or shower.



Electrical storms

Electrical storms can sometimes cause power surges harmful to electronic equipment. For your own safety, take caution when using electrical appliances during storms.

Cleaning your telephone

Your telephone has a durable plastic casing that should retain its luster for many years. Clean it only with a dry non-abrasive cloth. Do not use dampened cloth or cleaning solvents of any kind.

Technical specifications

Frequency control	<ul style="list-style-type: none"> • Crystal controlled PLL synthesizer
Transmit frequency	<ul style="list-style-type: none"> • Handset: 1921.536-1928.448 MHz • Telephone base: 1921.536-1928.448 MHz
Channels	<ul style="list-style-type: none"> • 5
Nominal effective range	<ul style="list-style-type: none"> • Maximum power allowed by FCC and IC. Actual operating range may vary according to environmental conditions at the time of use.
Power requirement  	<ul style="list-style-type: none"> • Handset: 2.4V Ni-MH battery • Telephone base: 6V DC @ 600mA • Charger: 6V DC @ 400mA
Memory	<ul style="list-style-type: none"> • Phonebook: 1200 memory locations; up to 30 digits and 15 characters • Caller ID log: 50 memory locations; up to 24 digits and 15 characters • Call block: 1000 entries

When it is fully charged, you can expect the following performance.

Operation	Operating time*
Talk time (cordless handset)	<ul style="list-style-type: none"> • 10 hours
Standby	<ul style="list-style-type: none"> • 5 days

* Operating times vary depending on your actual use and the age of the battery.

Frequently asked questions

Below are the questions most frequently asked about the cordless telephone. If you cannot find the answer to your question, visit our U.S. website at www.vtechphones.com or call **1 (800) 595-9511** for customer service. In Canada, go to phones.vtechcanada.com or call **1 (800) 267-7377**.

My telephone does not work at all.	Make sure the telephone base is installed properly, and battery is installed and charged correctly. For optimum daily performance, return the handset to the telephone base after use.
The display shows No line. I cannot hear the dial tone.	<p>Disconnect the telephone line cord from your telephone and connect it to another telephone. If there is no dial tone on that other telephone either, then the telephone line cord may be defective. Try installing a new telephone line cord.</p> <p>If changing the telephone line cord does not help, the wall jack (or the wiring to this wall jack) may be defective. Contact your telephone service provider.</p> <p>You may be using a new cable or VoIP service, the existing telephone jacks in your home may no longer work. Contact your service provider for solutions.</p>
I cannot dial out.	<p>Make sure there is a dial tone before dialing. It is normal if the handset takes a second or two to synchronize with the telephone base before producing a dial tone. Wait an extra second before dialing.</p> <p>Eliminate any background noise. Mute the handset before dialing, or dial from another room in your home with less background noise.</p>

What does this limited warranty cover?

The manufacturer of this VTech Product warrants to the holder of a valid proof of purchase ("Consumer" or "you") that the Product and all accessories provided in the sales package ("Product") are free from defects in material and workmanship, pursuant to the following terms and conditions, when installed and used normally and in accordance with the Product operating instructions. This limited warranty extends only to the Consumer for Products purchased and used in the United States of America and Canada.

What will VTech do if the Product is not free from defects in materials and workmanship during the limited warranty period ("Materially Defective Product")?

During the limited warranty period, VTech's authorized service representative will replace at VTech's option, without charge, a Materially Defective Product. If we replace the Product, we may use new or refurbished replacement parts. If we choose to replace the Product, we may replace it with a new or refurbished Product of the same or similar design. We will retain defective parts, modules, or equipment. Replacement of the Product, at VTech's option, is your exclusive remedy. VTech will return the replacement Products to you in working condition. You should expect the replacement to take approximately 30 days.

How long is the limited warranty period?

The limited warranty period for the Product extends for ONE (1) YEAR from the date of purchase. If VTech replaces a Materially Defective Product under the terms of this limited warranty, this limited warranty also applies to the replacement Product for a period of either (a) 90 days from the date the replacement Product is shipped to you or (b) the time remaining on the original one-year warranty; whichever is longer.

What is not covered by this limited warranty?

This limited warranty does not cover:

1. Product that has been subjected to misuse, accident, shipping or other physical damage, improper installation, abnormal operation or handling, neglect, inundation, fire, water or other liquid intrusion.

2. Product that has been subjected to contact with liquid, water, rain, extreme humidity or heavy perspiration, sand, dirt or the like; but then only to the extent the damage was not caused by incorrectly securing the waterproof handset's protective elements, for example, failing to properly close a seal), or such protective elements are damaged or missing (e.g. a cracked battery door), or subjecting a Product to conditions beyond its stated specifications or limits (e.g. 30 minutes in 1 meter of fresh water).
3. Product that has been damaged due to repair, alteration or modification by anyone other than an authorized service representative of VTech;
4. Product to the extent that the problem experienced is caused by signal conditions, network reliability, or cable or antenna systems;
5. Product to the extent that the problem is caused by use with non-VTech accessories;
6. Product whose warranty/quality stickers, product serial number plates or electronic serial numbers have been removed, altered or rendered illegible;
7. Product purchased, used, serviced, or shipped for repair from outside the United States of America or Canada, or used for commercial or institutional purposes (including but not limited to Products used for rental purposes);
8. Product returned without a valid proof of purchase (see item 2 below); or
9. Charges for installation or set up, adjustment of customer controls, and installation or repair of systems outside the unit.

How do you get warranty service?

To obtain warranty service in the USA, please visit our website at www.vtechphones.com or call 1 (800) 595-9511.

To obtain warranty service in Canada, go to phones.vtechcanada.com or dial 1 (800) 267-7377.

NOTE: Before calling for service, please review the user's manual - a check of the Product's controls and features may save you a service call.

Except as provided by applicable law, you assume the risk of loss or damage during transit and transportation and are responsible for delivery or handling charges incurred in the transport of the Product(s) to the service

Limited Warranty

location. VTech will return replaced Product under this limited warranty. Transportation, delivery or handling charges are prepaid.

VTech assumes no risk for damage or loss of the Product in transit. If the Product failure is not covered by this limited warranty, or proof of purchase does not meet the terms of this limited warranty, VTech will notify you and will request that you authorize the cost of replacement prior to any further replacement activity. You must pay for the cost of replacement and return shipping costs for the replacement of Products that are not covered by this limited warranty.

What must you return with the Product to get warranty service?

1. Return the entire original package and contents including the Product to the VTech service location along with a description of the malfunction or difficulty; and
2. Include a "valid proof of purchase" (sales receipt) identifying the Product purchased (Product model) and the date of purchase or receipt; and
3. Provide your name, complete and correct mailing address, and telephone number.

Other limitations

This warranty is the complete and exclusive agreement between you and VTech. It supersedes all other written or oral communications related to this Product. VTech provides no other warranties for this Product. The warranty exclusively describes all of VTech's responsibilities regarding the Product. There are no other express warranties. No one is authorized to make modifications to this limited warranty and you should not rely on any such modification.

State/Provincial Law Rights: This warranty gives you specific legal rights, and you may also have other rights, which vary from state to state or province to province.

Limitations: Implied warranties, including those of fitness for a particular purpose and merchantability (an unwritten warranty that the Product is fit for ordinary use) are limited to one year from the date of purchase.

Some states/provinces do not allow limitations on how long an implied warranty lasts, so the above limitation may not apply to you. In no event shall VTech be liable for any indirect, special, incidental, consequential, or similar damages (including, but not limited to lost profits or revenue, inability to use the Product or other associated equipment, the cost of substitute equipment, and claims by third parties) resulting from the use of this Product. Some states/provinces do not allow the exclusion or limitation of incidental or consequential damages, so the above limitation or exclusion may not apply to you.

Please retain your original sales receipt as proof of purchase

Disclaimer and Limitation of Liability

VTech Communications, Inc. and its suppliers assume no responsibility for any damage or loss resulting from the use of this user's manual. VTech Communications, Inc. and its suppliers assume no responsibility for any loss or claims by third parties that may arise through the use of this product.

Company: VTech Communications, Inc.

Address: 9020 SW Washington Square Road - Ste 555
Tigard, OR 97223, United States

Phone: 1 (800) 595-9511 in the U.S. or 1 (800) 267-7377
in Canada

Go to www.vtechphones.com **(US)** to register your product for enhanced warranty support and the latest VTech product news.

Go to phones.vtechcanada.com **(Canada)** for the latest VTech product news.



Specifications are subject to change without notice.

© 2026 VTech Communications, Inc.

All rights reserved. v3. 06/26